



**ESG35T, Super Runner and Super Marathon Series**

**Frymaster Dean Millivolt Gas  
Fryers  
Service & Parts Manual**



NON-CE  
&  
CE



Dean, a member of the Commercial Food Equipment Service Association, recommends using CFESA Certified Technicians.

**24-Hour Service Hotline  
1-800-551-8633**

[www.frymaster.com](http://www.frymaster.com)

Email: [service@frymaster.com](mailto:service@frymaster.com)

06/2015



8 1 9 5 9 4 8

**Please read all sections of this manual and retain for future reference.**

**NOTICE**

This appliance is intended for professional use only and is to be operated by qualified personnel only. A Frymaster Dean Factory Authorized Servicer (FAS) or other qualified professional should perform installation, maintenance, and repairs. Installation, maintenance, or repairs by unqualified personnel may void the manufacturer's warranty.

**NOTICE**

This equipment must be installed in accordance with the appropriate national and local codes of the country and/or region in which the appliance is installed.

**NOTICE**

Drawings and photos used in this manual are intended to illustrate operational, cleaning and technical procedures and may not conform to onsite management operational procedures.

**NOTICE**

IF, DURING THE WARRANTY PERIOD, THE CUSTOMER USES A PART FOR THIS MANITOWOC FOOD SERVICE EQUIPMENT OTHER THAN AN UNMODIFIED NEW OR RECYCLED PART PURCHASED DIRECTLY FROM FRYMASTER DEAN, OR ANY OF ITS AUTHORIZED SERVICE CENTERS, AND/OR THE PART BEING USED IS MODIFIED FROM ITS ORIGINAL CONFIGURATION, THIS WARRANTY WILL BE VOID. FURTHER, FRYMASTER DEAN AND ITS AFFILIATES WILL NOT BE LIABLE FOR ANY CLAIMS, DAMAGES OR EXPENSES INCURRED BY THE CUSTOMER WHICH ARISE DIRECTLY OR INDIRECTLY, IN WHOLE OR IN PART, DUE TO THE INSTALLATION OF ANY MODIFIED PART AND/OR PART RECEIVED FROM AN UNAUTHORIZED SERVICE CENTER.

** DANGER**

Improper installation, adjustment, maintenance or service, and unauthorized alterations or modifications can cause property damage, injury, or death. Read the installation, operating and service instructions thoroughly before installing or servicing this equipment. Only qualified service personnel may convert this appliance to use a gas other than that for which it was originally configured.

** DANGER**

Adequate means must be provided to limit the movement of this appliance without depending upon the gas line connection. Single fryers equipped with legs must be stabilized by installing anchor straps. All fryers equipped with casters must be stabilized by installing restraining chains. If a flexible gas line is used, an additional restraining cable must be connected at all times when the fryer is in use.

 **DANGER**

The front ledge of the fryer is not a step. Do not stand on the fryer. Serious injury can result from slips or contact with the hot oil.

 **DANGER**

Do not store or use gasoline or other flammable vapors and liquids in the vicinity of this or any other cooking appliance.

 **DANGER**

Instructions explaining procedures to be followed **MUST** be posted in a prominent location in the event the operator detects a gas leak. This information can be obtained from the local gas company or gas supplier.

 **DANGER**

The crumb tray in fryers equipped with a filter system must be emptied into a fireproof container at the end of frying operations each day. Some food particles can spontaneously combust if left soaking in certain shortening material. Additional information can be obtained in the filtration manual included with the system.

 **WARNING**

No structural material on the fryer should be altered or removed to accommodate placement of the fryer under a hood. Questions? Call the Frymaster Dean Service Hotline at 1-800-551-8633.

 **WARNING**

Do not bang fry baskets or other utensils on the fryer's joiner strip. The strip is present to seal the joint between the frypot. Banging fry baskets on the strip to dislodge shortening will distort the strip, adversely affecting its fit. It is designed for a tight fit and should only be removed for cleaning.

**IMPORTANT**

Safe and satisfactory operation of Frymaster Dean equipment depends upon its proper installation. Installation **MUST** conform with local codes, or in the absence of local codes, to European Community (CE) Standards.



**Frymaster Dean Millivolt Gas Fryers  
Service and Parts Manual**

**TABLE OF CONTENTS**

	<b>Page #</b>
<b>1. SERVICE PROCEDURES</b> .....	<b>1-1</b>
<b>1.1 Functional Description</b> .....	<b>1-1</b>
<b>1.2 Accessing Fryers for Servicing</b> .....	<b>1-3</b>
<b>1.3 Cleaning the Gas Valve Vent Tube</b> .....	<b>1-3</b>
<b>1.4 Check Burner Manifold Pressure</b> .....	<b>1-3</b>
<b>1.5 Adjusting the Pilot Flame</b> .....	<b>1-5</b>
<b>1.6 Replacing Fryer Components</b> .....	<b>1-5</b>
<b>1.6.1</b> Replacing the Operating Thermostat.....	<b>1-6</b>
<b>1.6.2</b> Replacing the High-Limit Thermostat.....	<b>1-7</b>
<b>1.6.3</b> Replacing the Gas Valve.....	<b>1-7</b>
<b>1.6.4</b> Replacing the Frypot.....	<b>1-7</b>
<b>1.7 Troubleshooting and Problem Isolation</b> .....	<b>1-8</b>
<b>1.7.1</b> Pilot Failures.....	<b>1-10</b>
<b>1.7.2</b> Improper Burner Functioning.....	<b>1-11</b>
<b>1.7.3</b> Improper Temperature Control.....	<b>1-11</b>
<b>1.7.4</b> Filtration Problems.....	<b>1-12</b>
<b>1.7.5</b> Leaking.....	<b>1-14</b>
<b>1.8 Wiring Diagrams</b> .....	<b>1-14</b>
<b>1.8.1</b> Current Production Units with Honeywell Gas Valve (Non-CE).....	<b>1-14</b>
<b>1.8.2</b> Current Production Units with Honeywell Gas Valve (CE).....	<b>1-15</b>
<b>1.8.3</b> Current Production Units with Robertshaw Gas Valve (After May, 2002).....	<b>1-16</b>
<b>1.8.4</b> UFF Filtration Wiring Diagram.....	<b>1-17</b>



**Frymaster Dean Millivolt Gas Fryers  
Service and Parts Manual**

**TABLE OF CONTENTS (CONT.)**

	<b>Page #</b>
<b>2. PARTS LIST.....</b>	<b>2-1</b>
<b>2.1 Cabinetry Components, Single Fryers.....</b>	<b>2-1</b>
<b>2.2 Cabinetry Components, Multi-Battery Systems.....</b>	<b>2-4</b>
<b>2.3 Component Box Components and Related Components (Non-CE and CE).....</b>	<b>2-6</b>
<b>2.4 Frypot and Burner System Components.....</b>	<b>2-8</b>
<b>2.4.1 SM220 and SM20/20/~ Systems.....</b>	<b>2-8</b>
<b>2.4.2 SR Series, ESG35T, SM35G, SM40G and SM50G Systems.....</b>	<b>2-10</b>
<b>2.4.3 SM60G and SM80G Systems.....</b>	<b>2-13</b>
<b>2.5 Oil Drain Manifold, Drain Flush and Drain Valve Components.....</b>	<b>2-16</b>
<b>2.6 Oil Return Manifold Components.....</b>	<b>2-20</b>
<b>2.7 Oil Return and Oil Flush Components.....</b>	<b>2-23</b>
<b>2.8 Under Fryer Filter (UFF) Components.....</b>	<b>2-27</b>
<b>2.8.1 SM50 and SM60 Series Fryers (Except IHOP).....</b>	<b>2-27</b>
<b>2.8.2 SM50 Series Fryers, IHOP UFF 50 with Filter Leaf.....</b>	<b>2-28</b>
<b>2.8.3 SM80 Series Fryers.....</b>	<b>2-29</b>
<b>2.9 Single Under Fryer Filter (SUFF) Components.....</b>	<b>2-30</b>
<b>2.9.1 SM50 Series Fryers.....</b>	<b>2-30</b>
<b>2.9.2 SM60 and SM80 Series Fryers.....</b>	<b>2-31</b>

# FRYMASTER DEAN MILLIVOLT GAS FRYERS

## CHAPTER 1: SERVICE PROCEDURES

### 1.1 Functional Description

Frymaster Dean ESG, Super Runner and Super Marathon Series fryers are millivolt fryers, which require no electricity to operate (systems with built-in filtration and/or other accessories will require electric power). Frymaster Dean millivolt fryers contain a welded steel frypot (stainless or cold-rolled) that is heated by gas flames diffused evenly through tubes built into the frypot. The number of tubes varies from three to five, according to the fryer model and size.

Flames originate from orifices in a burner manifold positioned beneath cast-iron burners. The burners are positioned in the tube openings, at the front of the frypot. Diffusers within each tube distribute the flame evenly throughout the tube. The diameter of the orifices differs for natural (CE:G20/G25) and LP (CE:G31) gas as indicated in the accompanying table.

<b>NON-CE (Altitudes of 2000 feet or less)</b>							
MODEL	INPUT (BTU)	GAS TYPE	ORIFICE MM (INCH)	ORIFICE PART NO.	QTY	EQUIPMENT PRESSURE	
						MBAR	INCH W.C.
SM20GM	50	NAT	2.18(#44)	8102050	2	10	4
		LP	1.40(#54)	8102324	2	27.5	11
ESG35T	70	NAT	2.18 (#44)	8104389	3	9.5	3.8
		LP	1.40(#54)	8103529	3	30	10
SM 35 (40) GM SR 42GM	105	NAT	2.80(#35)	8102040/*8103097	3	10	4
		LP	1.70(#51)	8102064/*8103099	3	27.5	11
SR 52 GM SM 50 GM	120	NAT	2.53(#39)	8102048	4	10	4
		LP	1.51(#53)	8102059	4	27.5	11
SR 62 GM SM 60 GM	150	NAT	2.53(#39)	8102048	5	10	4
		LP	1.51(#53)	8102059	5	27.5	11
SR 62 GM (Australia)	150	NAT	2.53(#39)	8102048	5	9	3.6
		LP	1.61(#52)	8102063	5	24	9.6
SM 80 GM	165	NAT	2.58(#38)	8102062	5	10	4
		LP	1.61(#52)	8102063	5	27.5	11
<b>CE ONLY (Altitudes of 2000 feet or less)</b>							
MODEL	INPUT (kW)	GAS TYPE	ORIFICE MM (INCH)	ORIFICE PART NO.	QTY/ COLOR	EQUIPMENT PRESSURE	
						MBAR	INCH W.C.
SM20GM	15	G20	2,40	8102060	2/BLUE	10,0	4,0
		G25	2,40	8102060	2/BLUE	15,0	6,0
		G31	1,51	8102059	2/RED	27,0	10,8
SM 35 (40) GM SR 42GM	26	G20	2,40	8102060/*8103101	3/BLUE	10,0	4,0
		G25	2,40	8102060/*8103101	3/BLUE	15,0	6,0
		G31	1,51	8102059/*8103102	3/RED	27,0	10,8
SR 52 GM SM 50 GM	30	G20	2,40	8102060	4/BLUE	10,0	4,0
		G25	2,40	8102060	4/BLUE	15,0	6,0
		G31	1,51	8102059	4/RED	27,0	10,8
SR 62 GM SM 60 GM	37,5	G20	2,40	8102060	5/BLUE	10,0	4,0
		G25	2,40	8102060	5/BLUE	15,0	6,0
		G31	1,51	8102059	5/RED	27,0	10,8
SM 80 GM	37,5	G20	2,40	8102060	5/BLUE	10,0	4,0
		G25	2,40	8102060	5/BLUE	15,0	6,0
		G31	1,51	8102059	5/RED	27,0	10,8

\*SR42 units built after 4/07.

## 1.1 Functional Description (cont.)

An electromechanical millivolt gas valve regulates gas flow to the burner manifold. Frymaster Dean millivolt fryers use a pilot ignition system to control burner firing.

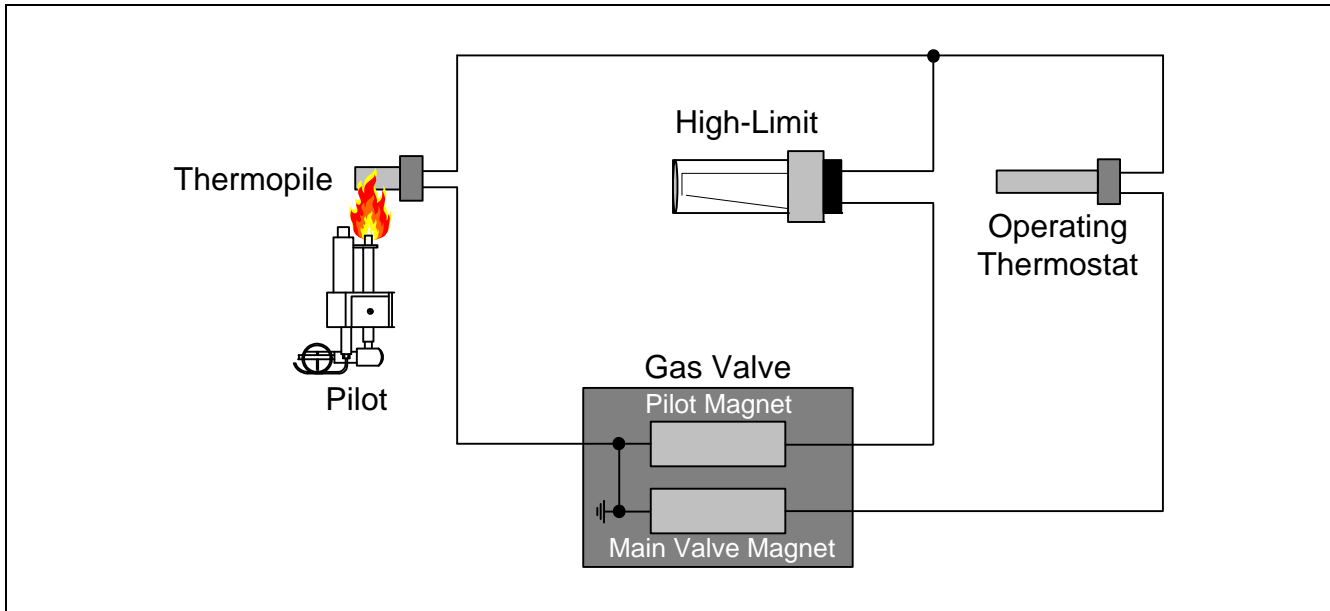

Functional diagram of a typical millivolt system.

### Pilot Ignition System

The pilot ignition system is made up of the pilot orifice, pilot hood, and a thermopile or thermocouple. The pilot serves two purposes: lighting the burner and heating the thermopile/thermocouple. In operation, the thermopile/thermocouple is in contact with the pilot flame and generates millivolts. The millivolt output passes through a normally closed high-limit switch and energizes the gas valve pilot coil, which in turn opens the pilot valve. If the pilot flame is extinguished, voltage is lost to the gas valve pilot coil and the pilot valve closes.

### Thermostats

Frymaster Dean millivolt fryers are equipped with adjustable *operating thermostats*. The temperature at which the thermostat opens and closes is adjusted by turning a knob.

Frymaster Dean millivolt fryers are also equipped with a *high-limit thermostat*. In the event that the fryer fails to properly control the oil temperature, the high-limit thermostat prevents the fryer from overheating to the flash point. The high-limit thermostat acts as a normally closed power switch that opens when exposed to temperatures above 410°F (210°C) for CE fryers and 435-450°F (224-232°C) for non-CE fryers. Once opened, the high limit must be manually reset before operating the fryer.

## 1.2 Accessing Fryers for Servicing



**Moving a fryer filled with cooking oil may cause spilling or splattering of the hot liquid.**

1. Drain all cooking oil from the fryer.
2. Shut off the gas supply to the unit and disconnect the unit from the gas supply.
3. Remove any attached restraining devices.



**Fryers must be at room temperature, empty of oil, and if fitted with legs, lifted during movement to avoid damage and possible bodily injury.**



**Hot shortening can cause severe burns. Avoid contact. Under all circumstances, oil must be removed from the fryer before attempting to move it to avoid oil spills, and the falls and severe burns that could occur. This fryer may tip and cause personal injury if not secured in a stationary position.**

4. Relocate the fryer for service accessibility. If fryer is equipped with legs, lift the fryer to relocate it. Damage to the leg or leg support channel can result if the fryer is not lifted when moving.
5. After servicing is complete, reconnect the unit to the gas supply and reattach the restraining devices.
6. Refill the frypot with cooking oil.

## 1.3 Cleaning the Gas Valve Vent Tube

1. Set the fryer power switch and the gas valve to the "OFF" position.
2. Carefully unscrew the vent tube from the gas valve. **NOTE:** The vent tube may be straightened for ease in removal.
3. Pass a piece of ordinary binding wire through the tube to remove any obstruction. Remove the wire and blow through the tube to ensure it is clear.
4. Reinstall tube and bend so that the opening is pointing downward.

## 1.4 Check Burner Manifold Pressure

**⚠ WARNING**

**This task should be performed by qualified service personnel only.**

1. Ensure that the gas valve knob is in the "OFF" position (non-CE), or press red button to turn gas valve off (CE).
2. Remove the pressure tap plug from the gas valve (see illustration below).

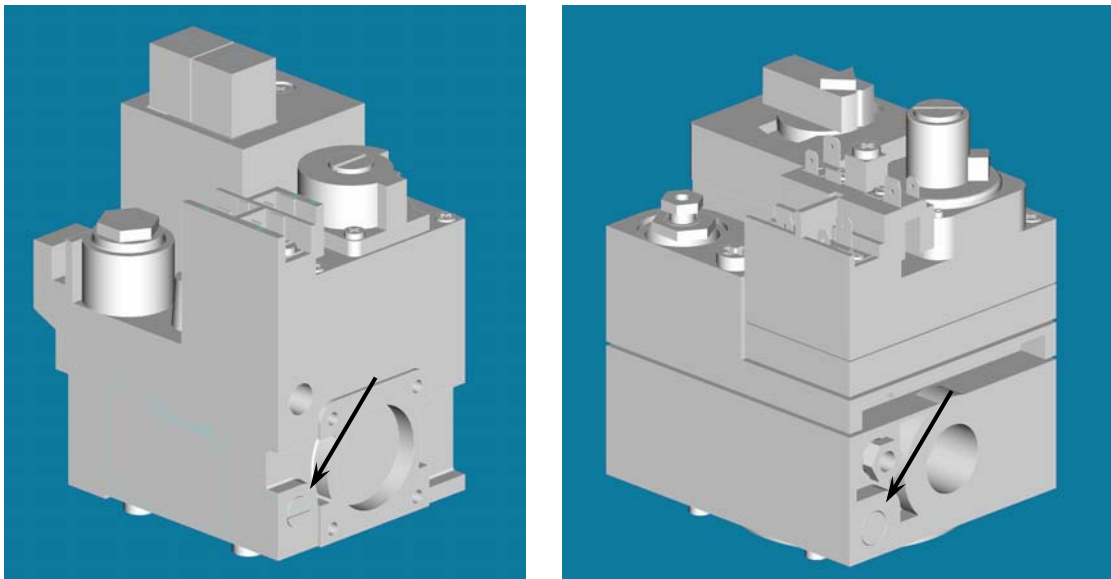

Pressure tap locations on CE gas valves (left) and non-CE gas valves (right).

3. Insert the fitting for a gas pressure-measuring device into the pressure tap hole.
4. Place the gas valve in the "Pilot" position (non-CE), or press white button and light pilot (CE). After the pilot is lit (turn non-CE gas valve to "ON" position), set thermostat knob to 350°F (177°C). When the burner lights and continues to burn, note gas pressure reading for correct pressure in accordance with the table on page 1-1.
5. To adjust burner gas pressure, remove the cap from the gas valve regulator and adjust to correct pressure.
6. Place the fryer power switch and the gas valve in the "OFF" position. Remove the pressure-measuring device fitting from the pressure tap hole and reinstall the pressure tap plug.
7. Repeat step 4 to continue fryer operation.

## 1.5 Adjusting the Pilot Flame

1. Remove the cover shown in the illustration below to access the pilot flame adjustment screw in the gas valve.

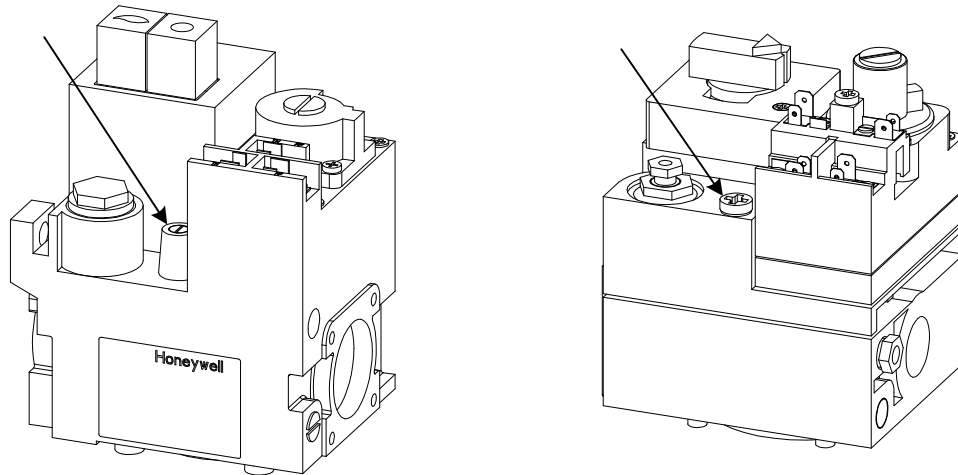

Pilot adjustment locations on CE gas valves (left) and non-CE gas valves (right).

2. Using a small, flat-tipped screwdriver, turn the pilot flame adjustment screw counterclockwise to increase the length of the flame or clockwise to decrease the length of the flame. Adjust the flame to a length of 1-½ inches (38 mm).
3. Reinstall the pilot flame-adjustment cover.
4. Five-tube millivolt fryers: Adjust the trailing pilot (adjustment valve located on the burner manifold) until a 1-½ inch (38 mm) flame is obtained.

## 1.6 Replacing Fryer Components

### 1.6.1 Replacing the Operating Thermostat

1. Drain the fryer and turn the gas off.
2. Remove the thermostat knob by pulling straight out on the knob with a firm, steady pull.
3. Disconnect the wires from the thermostat.
4. Remove the two mounting screws to release the thermostat control from its mounting bracket.
5. Remove the screws and clamp that secure the thermostat bulb to the frypot. Remove spring from bulb and reinstall on replacement thermostat bulb.

### 1.6.1 Replacing the Operating Thermostat (cont.)

6. First, loosen the capillary tube compression fitting until it slides freely on the capillary tube. Second, loosen the frypot pass-through nut until it slides freely on the capillary tube. Remove the capillary tube and bulb from the frypot.
7. Install the replacement thermostat capillary tube and bulb in the frypot. Apply a small amount of Loctite PST567 compound or equivalent to the threads of the frypot pass-through nut and screw the replacement thermostat securely into the frypot, being careful not to twist the capillary tube as the fitting is tightened. **DO NOT** tighten the capillary tube compression nut at this time.
8. Position the thermostat bulb in tube-mounted clamp and replace mounting hardware. Ensure probe bulb is properly positioned in the clamp ( $\frac{1}{4}$ " from burner tube) and screws are properly tightened.
9. Tighten the capillary tube compression nut once the capillary tube is properly positioned.  
NOTE: Once the compression nut is tightened, the capillary tube cannot be repositioned. If a mistake in installation has been made, a new thermostat will have to be installed.
10. Mount the thermostat control to the mounting bracket using the screws removed in Step 4.
11. Connect the wires disconnected in Step 3 to the thermostat.

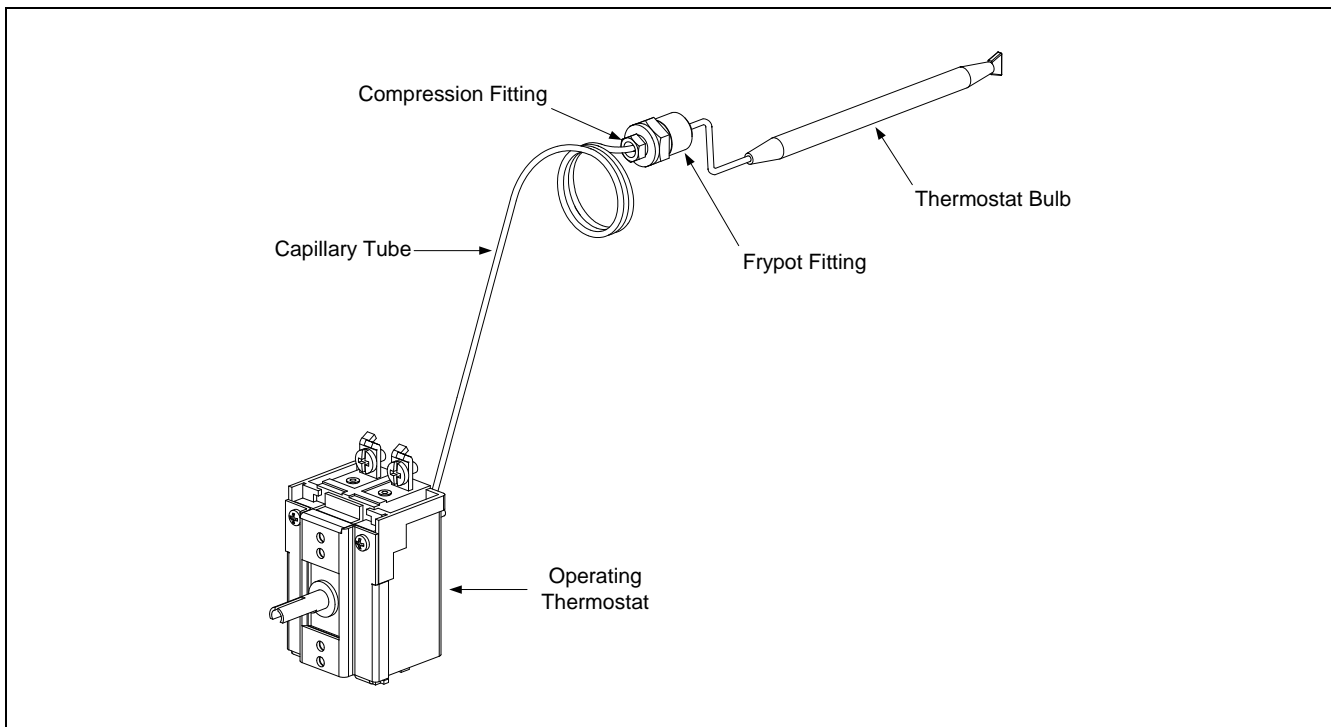

12. Install the thermostat knob on thermostat control shaft.

### 1.6.2 Replacing the High-Limit Thermostat

1. Follow instructions for replacing operating thermostat, section 1.7.1, omitting steps 2 and 12.

### 1.6.3 Replacing the Gas Valve



**Drain the frypot or remove the handle from the drain valve before proceeding further.**

1. Disconnect fryer from the gas supply.
2. Disconnect wiring from the gas valve terminal block, marking each wire to facilitate reconnection.
3. Disconnect the pilot gas line fitting from the gas valve and remove the vent tube.
4. Disconnect the union that connects burner manifold and gas valve piping.
5. Remove all pipefittings from old gas valve and install on new gas valve. Apply a small amount of Loctite PST567 compound or equivalent to pipe threads prior to installing on new valve. Do not apply compound to the first two pipe threads. Doing so will clog and damage the gas valve.
6. Reinstall new gas valve following steps 1-4 in reverse.

### 1.6.4 Replacing the Frypot

1. Drain the frypot and disconnect the fryer from the gas supply.
2. Remove all accessories (e.g., frypot covers, drop-in probes, basket hangers, etc.).
3. Remove the screws from the cabinet back and remove it from the fryer.
4. Remove the screws attaching the flue cap to the frypot and lift the flue cap off the fryer.
5. Remove the door by lifting it upward to disengage the lower hinge pin from the hinge bracket. Retain any spacers between lower hinge and door for reassembly.
6. Remove the screws from the front cowling and remove the cowling by lifting up and out off the front lip of the frypot.
7. Remove the screws securing the flue to the frypot and remove it from the fryer.
8. Lift the frypot out of the cabinet, using care not to bump or damage the gas valve/burner assembly or the thermostat/high-limit. Set the frypot upside down on a clean surface for removal of the remaining components.

#### 1.6.4 Replacing the Frypot (cont.)

9. Recover the drain valve, high-limit thermostat, operating thermostat, and burner manifold assembly from the failed frypot.
10. Clean the threads on the recovered parts, apply Loctite PST 567 or equivalent thread sealer, and install them on the replacement frypot.
11. Reverse Steps 1-9 to install the replacement frypot in the cabinet.

**For SUFF/UFF Filtration-equipped systems, consult the Decathlon Series Gas Fryers Service & Parts Manual (819-5922), Section 1.7.8, for detailed frypot-removal instructions.**

### 1.7 Troubleshooting and Problem Isolation

This section is intended to provide technicians with a general knowledge of the broad problem categories associated with this equipment, and the probable causes of each. With this knowledge, the technician should be able to isolate and correct any problem encountered.

Problems you are likely to encounter can be grouped into these broad categories:

1. Pilot failures
2. Improper burner functioning
3. Improper temperature control
4. Filtration Problems
5. Leaking

The probable causes and corrective actions for each category are discussed in the following sections.

#### 1.7.1 Pilot Failures

When troubleshooting millivolt systems, always check these areas before performing diagnostic checks on either the Robertshaw or Honeywell systems:

- A. Inspect all wires and component leads for damage (heat, oil, moisture, etc.). On capillary tube-type thermostats, check for resistance on the thermostat lead wires. Wire nuts and other connectors cannot be present in a millivolt circuit as they can cause resistance. If resistance is found, solder the connectors to the wires or replace the wires.
- B. Clean and verify that all wire connections and gas valve terminal connections are tight.
- C. Check the length of the pilot flame (it should be about 1½-inches (38mm) long) and verify that it contacts the top one third of the thermopile. Clean the pilot orifice and adjust the pilot strength if needed.
- D. Measure thermopile output with no load (i.e., with the thermopile disconnected from the gas valve). Measurement must be made with a multimeter having a 0-1000 DC millivolt (MV) range. Light the pilot and have someone hold the gas cock knob in the depressed position. If the thermopile is a single lead (coaxial) type, measure from the lead's end contact to its screw-in threads. If the thermopile has two leads, measure across the end terminals. The reading should be within the range of 500-800 millivolts. If not, replace the thermopile.

Performing diagnostic checks on Robertshaw and Honeywell valves are described on the next page.

## ROBERTSHAW-UNITROL 7000 SYSTEM CHECK

### 1. Complete System Check

With thermostat contacts closed and gas cock dial in the "ON" position, the main burner should ignite. Measure the reading between the 2 & 3 terminals. If the reading is more than 100MV, replace the gas valve.

### 2. System Resistance Check

With thermostat contacts closed and main burner "ON", measure the millivolt reading between the 1 and 3 terminals. The reading should be less than 80MV. If not, recheck the thermostat leads and connections. Replace with new or heavier gauge wires if necessary. If the reading is still greater than 80MV, replace the thermostat.

### 3. Automatic Pilot Dropout Check

With the thermostat contacts open, hold the gas cock knob depressed with the pilot lit until the maximum millivolt output is observed between the 1 and 2 terminals. Then extinguish the pilot and observe the meter. The sound of the pilot magnet dropping should be audible. This dropout should occur between 120MV and 30MV. If it occurs outside these limits, change the gas valve.

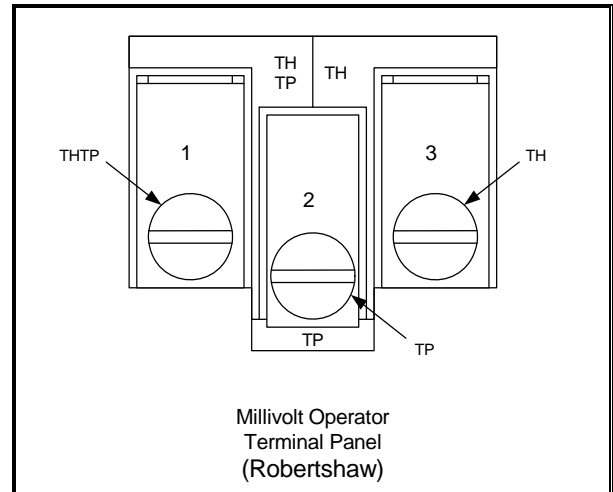

Test	Meter Setting	Meter Leads On Terminals	Acceptable Results
1	MV	2 & 3	<100MV
2	MV	1 & 3	<80MV
3	MV	1 & 2	30-120MV

## HONEYWELL SYSTEM CHECK

### 1. Complete System Check

With thermostat contacts closed and gas cock dial in the "ON" position, main burner should ignite. If not, measure across terminals 2 and 3 as indicated in the diagram. If the reading is more than 180MV, replace the gas valve.

### 2. System Resistance Check

With thermostat contacts closed and main burner "ON", measure the millivolt reading between terminals 1 and 3 as indicated in the diagram. The reading should be 220MV or less. If not, recheck thermostat leads and connections. Replace with new or heavier gauge wires if necessary. If the reading is still greater than 220MV, replace the thermostat.

### 3. Automatic Pilot Dropout Check

With the thermostat contacts open, hold the gas cock knob depressed with the pilot lit until the maximum millivolt output is observed between terminals 1 and 2. Then extinguish the pilot and observe the meter. The sound of the pilot magnet dropping should be audible. This dropout should occur between 110MV and 36MV. If it occurs outside these limits, change the gas valve.

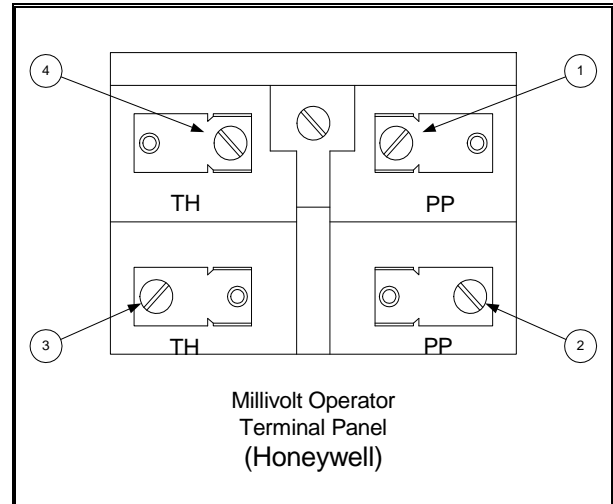

Test	Meter Setting	Meter Leads On Terminals	Acceptable Results
1	MV	2 & 3	<180MV
2	MV	1 & 3	<220MV
3	MV	1 & 2	36-110MV

Pilot failures fall into one of two categories – failure to light or failure to remain lit.

### Pilot Fails to Light

1. Gas is not being supplied to the valve: Check for a closed gas cutoff valve upstream of the gas valve. Also verify that the gas line quick disconnect fitting at the rear of the fryer (if so equipped) is properly connected.
2. Blocked pilot orifice: If gas is reaching the valve but the pilot will not light, check for an obstruction in the pilot orifice, especially in new installations. If the orifice is clear, check to be sure that the pilot adjustment screw is not completely closed.

### Pilot Does Not Remain Lit When Gas Valve Knob is Released

The gas valve used on Frymaster Dean millivolt fryers has a pair of normally open coils (electromagnetic switches) that close when low voltage is applied to them. If the coils do not close, the valve will not open to supply gas to the pilot or to the burner manifold. Turning the gas valve knob to the pilot position and pressing it in bypasses the pilot coil, allowing the pilot to be lit. The pilot flame heats the thermopile, which generates the voltage required to close the coils. If the pilot flame goes out when the knob is released, there are four probable causes:

1. **Open or grounded high-limit:** The high-limit thermostat functions as a normally closed switch. If the high-limit is open or grounded, the gas valve coil will not pull in and no gas will be supplied to the pilot or to the burner manifold.

**Check and Corrective Action:** Detach the high-limit leads from the gas valve and check for continuity. See page 1-10. If the high-limit fails the continuity check, it must be replaced.

2. **Loose/corroded wiring connections on high-limit or thermopile:** This has the same effect as a grounded or open high-limit. If the gas valve coils do not receive the appropriate voltage from the thermopile, they will not close and no gas will be supplied to the pilot or to the burner manifold.

**Check and Corrective Action:** Check wiring connections for corrosion and tightness. Check terminals to verify that they are securely attached to their leads.

3. **Low or no voltage out of thermopile:** If the pilot flame does not surround the tip of the thermopile, it will not generate sufficient voltage to the gas valve coils for them to close. No gas will be supplied to the pilot or to the burner manifold.

**Checks and Corrective Actions:** Observe pilot flame located between the middle burners on the frypot. If the pilot flame is less than 1-½ inches (38 mm) adjust the pilot flame in accordance with Section 1.6. If the flame is being blown away from the thermopile, eliminate the draft that is causing the problem.

If the pilot flame correctly surrounds the tip of the thermopile, see D on Page 1-9.

4. **Malfunctioning gas valve:** If either of the coils in the gas valve fails, no gas will be supplied to the pilot or to the burner manifold.

**Check and Corrective Action:** See page 1-10 for check procedures to see if the gas valve has failed. Instructions to replace the gas valve are found in section 1.7.3.

## 1.7.2 Improper Burner Functioning

*Fluctuating flame intensity* is normally caused by improper or fluctuating incoming gas pressure, but may also be the result of variations in the kitchen atmosphere. Variation in the kitchen atmosphere is usually caused by air conditioning and/or ventilation units starting and stopping. Changes in airflow patterns can also affect flame intensity. If the incoming gas pressure is correct and stable, check for variations in the kitchen atmosphere.

*Flames "rolling" out of the fryer* are usually an indication of negative pressure in the kitchen. Air is being sucked out of the fryer enclosure and the flames are literally following the air. If negative pressure is not the cause, check for high burner-manifold gas pressure. An obstructed flue, which prevents the fryer from properly exhausting, may also be the cause.

An *excessively noisy burner*, especially with *flames visible above the flue opening*, may indicate that the burner gas pressure is too high, the gas valve vent tube is blocked, or the tube diffusers are damaged or worn out. If the gas pressure is correct, the vent tube is unobstructed, and the diffusers are in good condition, the gas valve regulator is probably defective.

Occasionally a burner may appear to be operating correctly, but the fryer has a *slow recovery rate* (the length of time required for the fryer to increase the oil temperature from 275°F to 325°F (135°C to 163°C)). The primary causes of this are low burner manifold pressure and/or misaligned burners. If both of these causes are ruled out, the probable cause is a gas valve regulator that is out of adjustment. Refer to the **Check Burner Manifold Pressure** procedure in section 1.5.

## 1.7.3 Improper Temperature Control (i.e., failure to control at set point)

Temperature control is a function of several interrelated components, each of which must operate correctly. The principal component, however, is the thermostat.

The thermostat must be checked periodically.

Probable causes for temperature problems are damage to the thermostat bulb, kinking of the capillary tube, and broken or loose wiring. Inspect the thermostat components for visible damage.

If there are dents in the bulb, if the capillary is kinked, or if there is obvious damage to the leads, the thermostat should be replaced.

If there is no obvious damage to the thermostat, turn off the gas valve and allow the cooking oil to cool to at least 15 degrees below the thermostat setting. Disconnect the thermostat leads from the gas valve and check for continuity. If the thermostat fails the continuity check, it must be replaced.

## 1.7.4 Filtration Problems

The majority of filtration problems arise from operator error. One of the most common errors is placing the filter paper on the bottom of the filter pan rather than over the filter screen.

Whenever the complaint is "the pump is running, but no oil is being filtered", check the installation and size of the filter paper. Verify that the O-ring on the slip-connection is in good condition. A missing or worn O-ring allows the pump to suck air, decreasing its efficiency.

If the pump motor overheats, its thermal overload will trip and the motor will not start until it is reset. If the pump motor does not start, press the red reset switch located on the rear of the motor. Also, reset the filter circuit breaker located under the fryer control panel. If the pump then starts, something caused the motor to overheat. Maybe several frypots were filtered one after the other and the pump got hot. Letting the motor cool down for at least a half-hour is all that is required in this case. More often, the pump overheated for one of the following reasons:

- If solid shortening is used: Shortening solidified in the pan or filter lines.
- The operator attempted to filter unheated oil. Cold oil is thicker and causes the pump motor to work harder and overheat.

If the motor runs but the pump does not, there is a blockage in the pump. Incorrectly sized or installed paper allows food particles and sediment to pass through the filter pan and into the pump. When sediment enters the pump, the gears bind up causing the motor to overheat, tripping the thermal overload. Solidified shortening in the pump will produce the same result.

A pump seized by debris or hard shortening must be disassembled, cleaned and reassembled.

1. Disconnect power to the filter system.
2. Remove the front cover of the pump to access the gears inside (see illustration- 8-GPM pump shown), if the pump is accessible while still inside the cabinet. If the front cover is not accessible, the pump must be removed from the pump motor (remove input/output plumbing from the pump prior to removing pump). Remove three setscrews to disengage the pump from the motor.

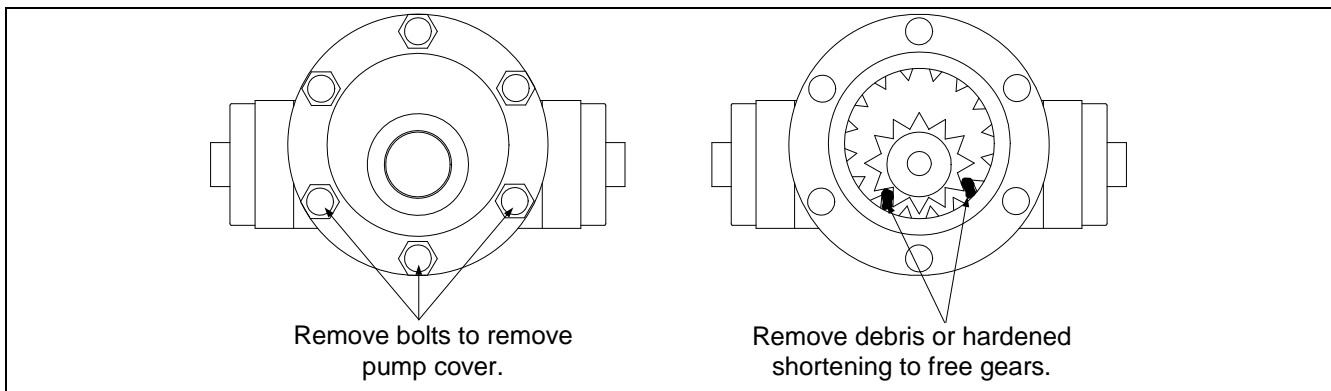

### 1.7.4 Filtration Problems (cont.)

3. Prior to reassembly, the inside housing must be clean and free of any sediment or debris. Failure to completely clean the inside housing and ring gear will cause gear binding after reassembly.

Incorrectly sized or installed paper will allow food particles and sediment to pass through and clog the suction tube on the bottom of the filter carriage. Particles large enough to block the suction tube may indicate that the crumb tray is not being used.

Pan blockage can also occur if shortening is left in the pan and allowed to solidify. Heater strips (if equipped) on the oil return plumbing are designed to prevent solidification of shortening left in the plumbing. Heater strips will not melt or prevent solidification of shortening in the pan.

Blockage removal can be accomplished by forcing the item out with an auger or drain snake. Compressed air or other pressurized gases should not be used to force out the blockage.

The electronics of the SUFF/UFF filtration systems are simple and straightforward. Microswitches, attached to handles for each vat and wired in parallel, provide the 24 VAC required to activate the pump relay coil when the handles are moved to the ON position. The activated pump relay coil pulls in the pump motor switch, supplying power to the pump motor.

Filter systems equipped with oil-return heaters are wired into the 120 VAC source, which remain energized as long as the unit is plugged in.

### 1.7.5 Leaking

Leakage of the frypot usually will be due to improperly sealed high-limits, thermostats, or drain fittings. When installed or replaced, each of these components must be sealed with Loctite PST567 sealant or equivalent to prevent leakage. In very rare cases, a leak may develop along one of the welded edges of the frypot. When this occurs, the frypot must be replaced.

If the sides and/or ends of the frypot are coated with oil, the most likely cause is spillage over the top of the frypot rather than leakage.

Frypot locations (indicated by arrows) where potential leaks could occur.

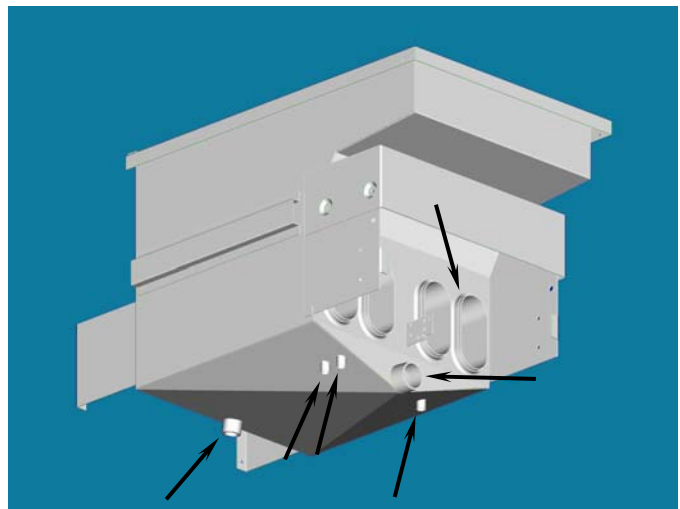

# 1.8 Wiring Diagrams

## 1.8.1 Current Production Units with Honeywell Gas Valve (Non-CE)

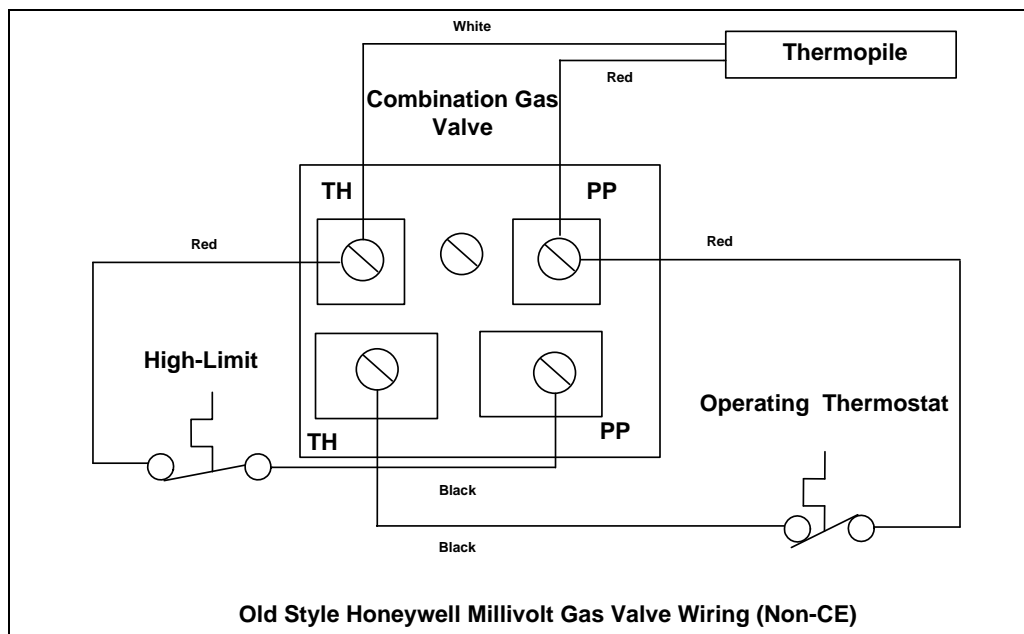
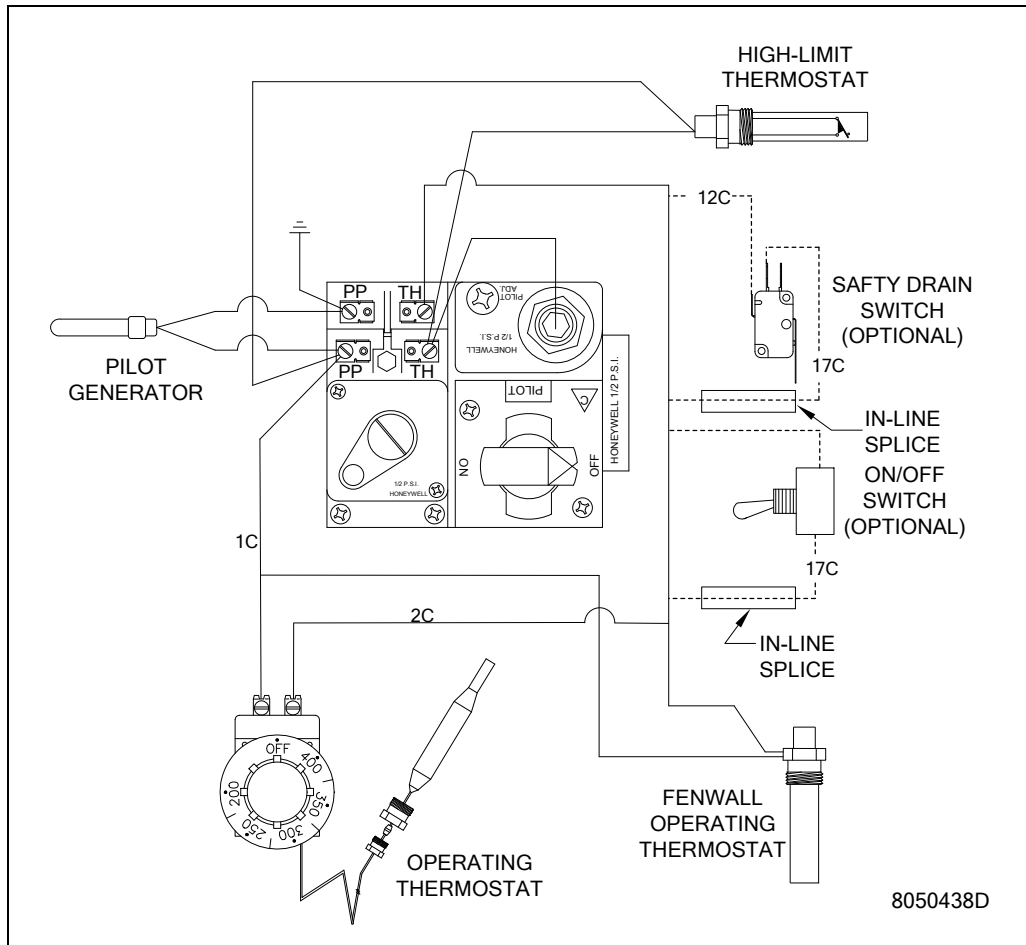

### 1.8.2 Current Production Units with Honeywell Gas Valve (CE)

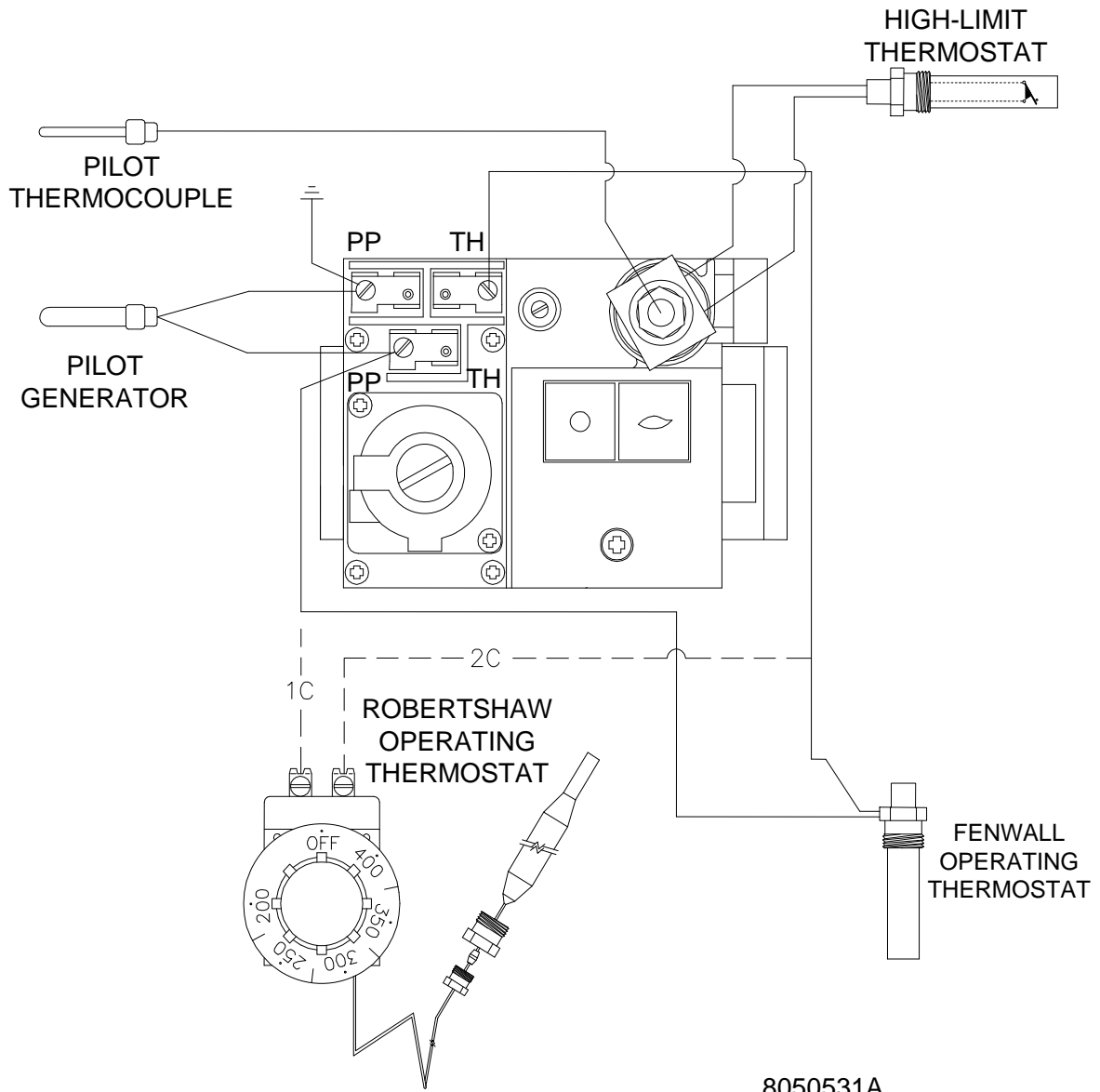

### 1.8.3 Current Production Units with Robertshaw Gas Valve (After May, 2002)

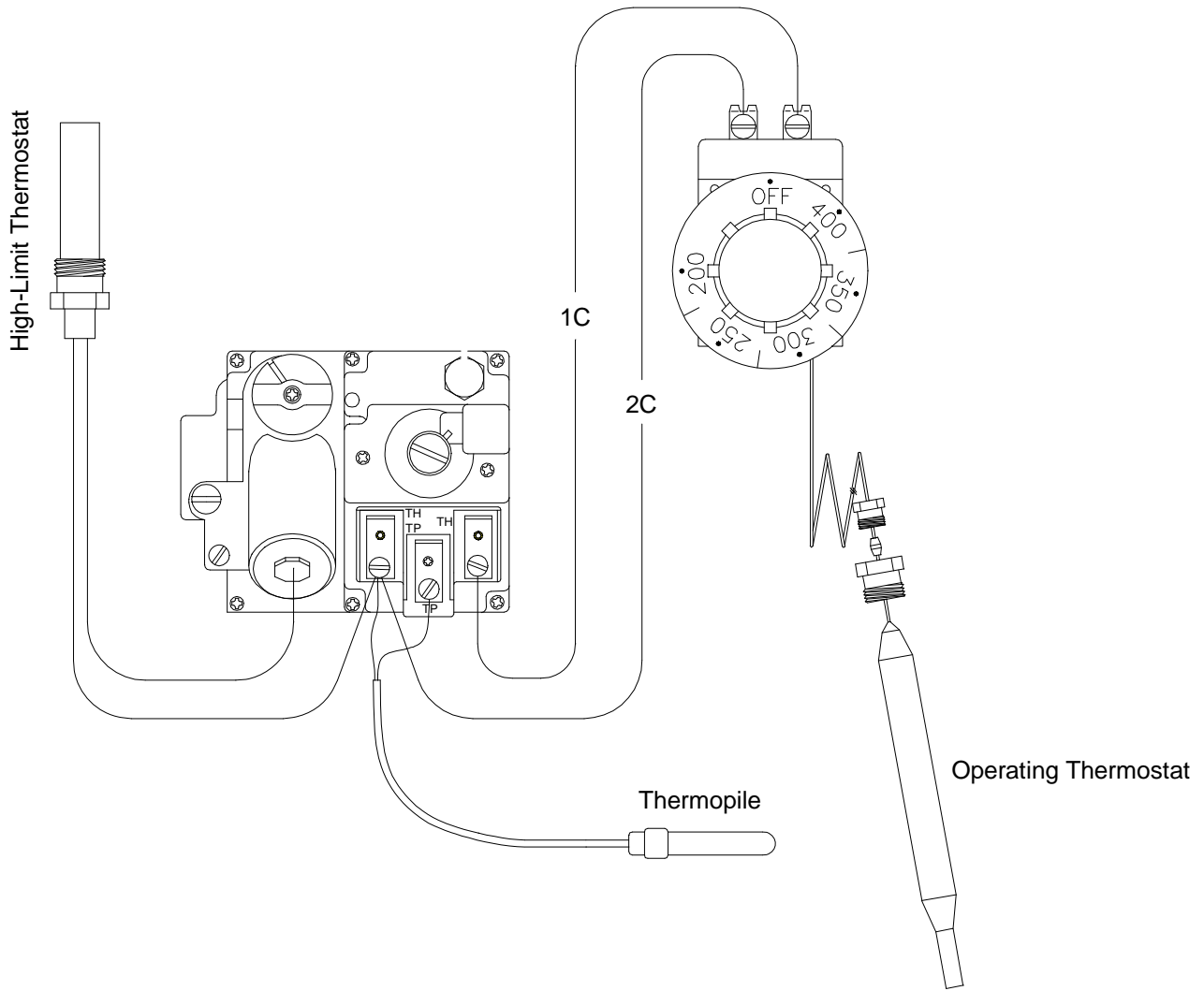



# FRYMASTER DEAN MILLIVOLT GAS FRYERS

## CHAPTER 2: PARTS LIST

### 2.1 Cabinetry Components, Single Fryers

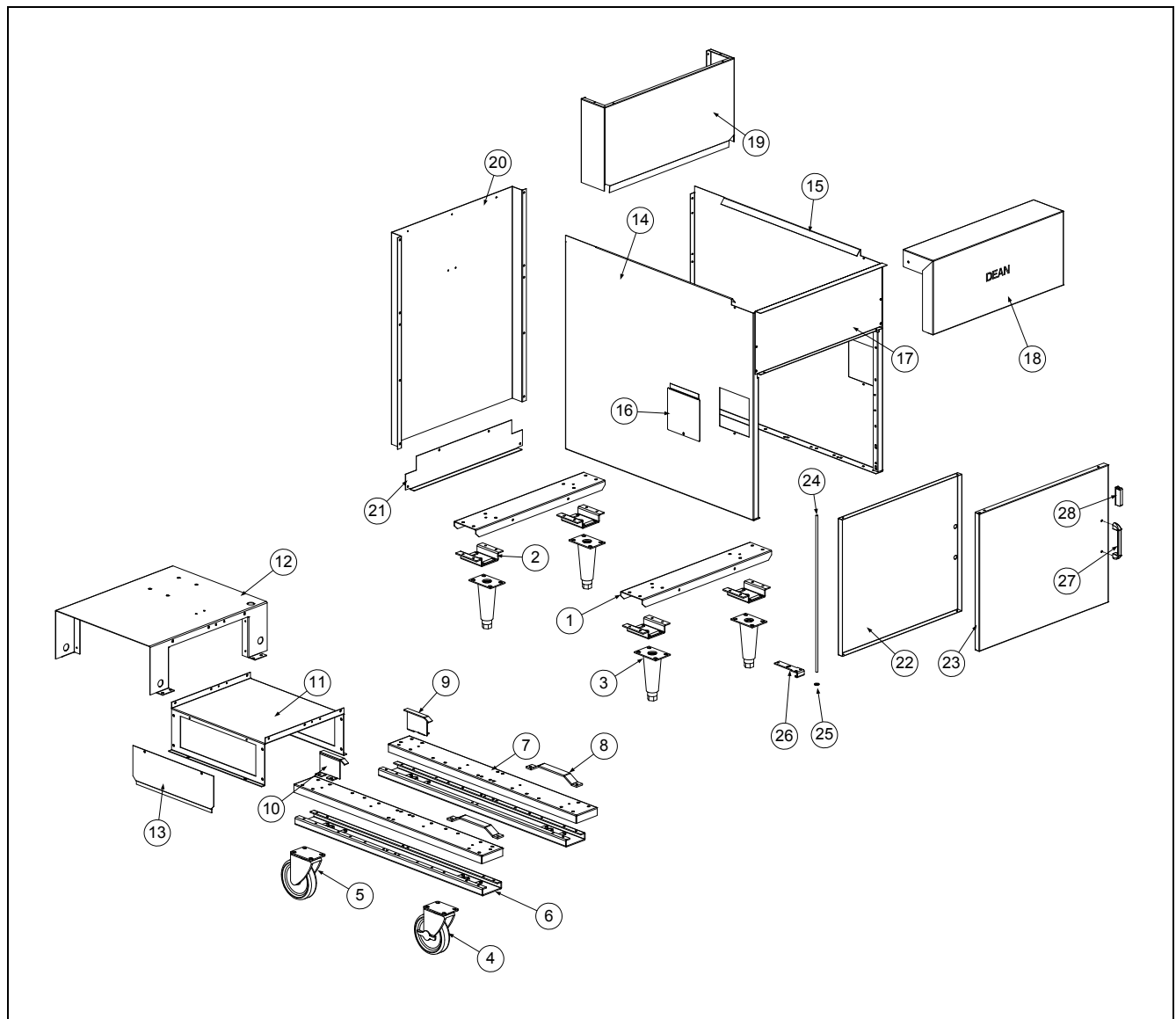

ITEM	PART #	COMPONENT
*	8102793	Basket Hanger SR142, ESG35T (Hook Over the Flue) Thumbscrews not needed
*	2001360	Basket Hanger SR42 (Thumbscrew 8090171, Cage Nut 8261351)
*	2101595	Basket Hanger SM-50 Single (Use 2103131 for double)
*	2105109	Joiner Strip SM20, SM50
1		<b>Channel, Base- Front &amp; Rear (Non-Filtration Single Fryers)</b>
*	2401341	Channel, Base- Front & Rear- ESG35T
*	2001118	Channel, Base- Front & Rear- SR42G, SR52G, SM220G SM35G, SM40G, SM50G
*	2005655	Channel, Base- Front & Rear-SR62G
*	2003269	Channel, Base- Front & Rear- SM20G
*	2002493	Channel, Base- Front & Rear- SM60G
*	2002686	Channel, Base- Front & Rear- SM80G
2	8233248	Support, Leg (Use Where Applicable)
3	8063168	Leg, Adjustable- With Mounting Plate- <u>All Millivolt Fryers</u>

\* Not Illustrated

**FRYMASTER DEAN MILLIVOLT GAS FRYERS  
CHAPTER 2: PARTS LIST**

**2.1 Cabinetry Components, Single Fryers (cont.)**

<b>ITEM</b>	<b>PART #</b>	<b>COMPONENT</b>
4	8100357	Caster, Swivel- With Brake- All Millivolt Fryers
5	8100356	Caster, Swivel- Without Brake- All Millivolt Fryers
<b>SUFF Base Components- SM Series With SUFF Filtration</b>		
6	8233791	Support, Leg- Left- SUFF 50- <b>SM40G, SM50G</b>
*	8233792	Support, Leg- Right- SUFF 50- <b>SM40G, SM50G</b>
*	8233724	Support, Leg- Left & Right- SUFF 60/80- <b>SM60G, SM80G</b>
7	2023529	Base, Channel- Right- SUFF 50- <b>SM40G, SM50G</b>
*	2013259	Base, Channel- Left- SUFF 50- <b>SM40G, SM50G</b>
*	2003459	Base, Channel- Right & Left- SUFF 60/80- <b>SM60G, SM80G</b>
8	2103636	Slide, Front- SUFF Filter, All Systems
9	8233751	Slide, Rear, Left- SUFF Filter- <b>SM60G, SM80G</b>
*	8233788	Slide, Rear, Left- SUFF Filter- <b>SM50G</b>
10	8233752	Slide, Rear, Right- SUFF Filter- <b>SM60G, SM80G</b>
*	8233789	Slide, Rear, Right- SUFF Filter- <b>SM50G</b>
11	2003522	Base, Lower Filter- SUFF 50- <b>SM40G, SM50G</b>
*	2003494	Base, Lower Filter- SUFF 60- <b>SM60G</b>
*	2003403	Base, Lower Filter- SUFF 80- <b>SM80G</b>
12	8233783	Base, Upper Filter- SUFF 50- <b>SM40G, SM50G</b>
*	8233765	Base, Upper Filter- SUFF 60- <b>SM60G</b>
*	8233745	Base, Upper Filter- SUFF 80- <b>SM80G</b>
13	2003524	Cover, Electrical Access- SUFF 50- <b>SM40G, SM50G</b>
*	2003461	Cover, Electrical Access- SUFF 60- <b>SM60G, SM80G</b>
14		<b>Side Panel, Left</b>
*	2113329	Side Panel, Left- <b>SM20G</b>
*	2012858	Side Panel, Left- Painted CRS- <b>SM35G, SM50G</b>
*	2011299	Side Panel, Left- Painted CRS- <b>SM50GDD</b>
	2212035SP	Side Panel, Left- Galvanized- <b>SR42G, ESG35T, SR52G (Use 2025693SP for SR62G)</b>
*	2112076	Side Panel, Left- S/S- <b>SR42G, SM35G, SM50G (Use 2115693 for SR62G)</b>
*	2112532	Side Panel, Left- S/S- <b>SM60G, SM80G</b>
15		<b>Side Panel, Right</b>
*	2123329	Side Panel, Right- <b>SM20G</b>
*	2022858	Side Panel, Right- Painted CRS- <b>SM35G, SM50G</b>
*	2021299	Side Panel, Right- Painted CRS- <b>SM50GDD</b>
	2222035SP	Side Panel, Right- Galvanized- <b>SR42G, ESG35T, SR52G (Use 2025693SP for SR62G)</b>
*	2122076	Side Panel, Right- S/S- <b>SR42G, SM35G, SM50G (Use 2125693 for SR62G)</b>
*	2122532	Side Panel, Right- S/S- <b>SM60G, SM80G</b>
16	2102804	Duct, Door Access- S/S- <u>All Millivolt Fryers</u>
*	2001471	Duct, Door Access- Painted- <u>All Millivolt Fryers</u>
17	2001121	Back, Control Panel- <b>SR42G, ESG35T, SR52G, SM220G (Use 2003003 for SR62G)</b>
*	2001676	Back, Control Panel- <b>SM35G, SM40G, SM50G</b>
*	2003558	Back, Control Panel- <b>SM50GDD</b>
*	2002856	Back, Control Panel- <b>SM60G</b>
*	2001213	Back, Control Panel- <b>SM60G</b>
*	2003004	Back, Control Panel- <b>SM80G</b>
18	2601417	Top Cap (Front Canopy)- <b>ESG35T</b>
*	2101141	Top Cap (Front Canopy)- <b>SR42G, SR52G, SM35G, SM40G, SM50G</b>
*	070132	Top Cap (Front Canopy)- <b>SM20G obsolete</b>
*	8241033	Top Cap (Front Canopy)- <b>SM220G</b>

\* Not Illustrated

**FRYMASTER DEAN MILLIVOLT GAS FRYERS  
CHAPTER 2: PARTS LIST**

**2.1 Cabinetry Components, Single Fryers (cont.)**

<b>ITEM</b>	<b>PART #</b>	<b>COMPONENT</b>
*	2103419	Top Cap (Front Canopy)- <b>SM50GDD</b>
*	2102821	Top Cap (Front Canopy)- <b>SM60G, SR62G</b>
*	2102811	Top Cap (Front Canopy)- <b>SM80G</b>
19	2601342	Flue Cap- <b>SR42G, ESG35T, SR52G (Sep. 2005 to Current)</b>
*	8234175	Flue Cap- <b>SR42G, SR52G (Feb. 2003 – August 2005 )</b> obsolete
*	8234437	Flue Cap- <b>SR62G</b>
*	8233467	Flue Cap- <b>SM35G, SM40G (SR42G, SR52G Prior To Feb. 2003)</b> obsolete
*	8233700	Flue Cap- <b>SM20G</b>
*	8233702	Flue Cap- <b>SM220G</b>
*	8233521	Flue Cap- <b>SM50G</b>
*	8233575	Flue Cap- <b>SM50GDD</b>
*	8233635	Flue Cap- <b>SM60G</b>
*	8233512	Flue Cap- <b>SM80G</b>
20	2401344	Back, One-Piece Cabinet- <b>SR42G, ESG35T, SR52G, SM50G (after July 2010)</b>
*	2001377	Back, One-Piece Cabinet- <b>SM35G, SM50G (before July 2010)</b>
*	2001123	Back, Upper Cabinet- <b>SR42G, SR52G, SM35G, SM50G</b>
*	2001674	Back, Upper Cabinet- <b>SM50G (SUFF), SM220G</b>
*	2001213	Back, Upper Cabinet- <b>SM60G / SR62G</b>
*	2002683	Back, Upper Cabinet- <b>SM80G</b>
21	2001126	Back, Lower Cabinet- <b>SM35G, SM50G, SM50GDD</b>
*	2001327	Back, Lower Cabinet- <b>SM60G</b>
*	2102684	Back, Lower Cabinet- <b>SM80G</b>
<b>Door Assembly Components</b>		
22	2003807	Panel, Inner Door- <b>SM20G</b>
*	2001379	Panel, Inner Door- <b>SM220G, SM35G, SM40G, SM50G</b>
*	2001185	Panel, Inner Door- <b>SM60G</b>
*	2002688	Panel, Inner Door- <b>SM80G</b>
23	1203082	Panel, Door- <b>SR38G</b> <i>obsolete</i>
*	2105241	Panel, Door- <b>SR42G, ESG35T, SR52G (Assembly 1063150SP)</b>
*	2105642	Panel, Door- <b>SR62G (Assembly 1063444SP)</b>
*	1064728	Door Assembly, <b>Right with Liner- SM50</b>
*	2103805	Panel, Outer Door- <b>SM20G (Assembly 106-2482SP)</b>
*	2102869	Panel, Outer Door- <b>SM220G, SM35G, SM40G, SM50G (Assembly 1061754SP)</b>
*	2101424	Panel, Outer Door- <b>SM60G</b>
*	2101151	Panel, Outer Door- <b>SM80G (Assembly 1061698SP)</b>
24	2001301	Pin, Door- <u>All Millivolt Fryers</u> (Use 8261343 for Springs qty. 10)
*	1061698SP	Pin, Door Assembly- All Millivolt Fryers (short)
25	8090413	Spacer, Nylon- <u>All Millivolt Fryers</u>
26	2001307	Hinge, Door- Lower- <b>All SR Series Fryers</b>
*	2001675	Hinge, Door- Lower- <b>All SM Series Fryers</b>
27	8100180	Handle, Door- Chrome- <b>All SM Series Fryers</b>
*	8090918	Screw, #10-24 x 1/2" (Use With 8102105)
*	8090191	Washer, Lock 1/4" (Use With 8102105)
*	8101422	Handle, Wireform- Door- <b>SR42G, SR52G (Use 8102030 before Jan. 03)</b>
*	8261379	Screw, #10 x 1/2" Round Phillips (Qty: 10) (Use With 810-1422)
28	8100066	Catch, Magnetic Door- <u>All Millivolt Fryers</u>
*	8233225	Splash Guard <b>42's &amp; 50's (Use 8234767 for 60's &amp; 80's)</b>
*	2003663	Striker Plate all models except <b>SR42</b>
*	2102897	Striker Plate <b>SR42</b>
*	8030197	Fryers Friend Cleanout Tool

\* Not Illustrated

**FRYMASTER DEAN MILLIVOLT GAS FRYERS  
CHAPTER 2: PARTS LIST**

**2.2 Cabinetry Components, Multi-Battery Frying Systems**

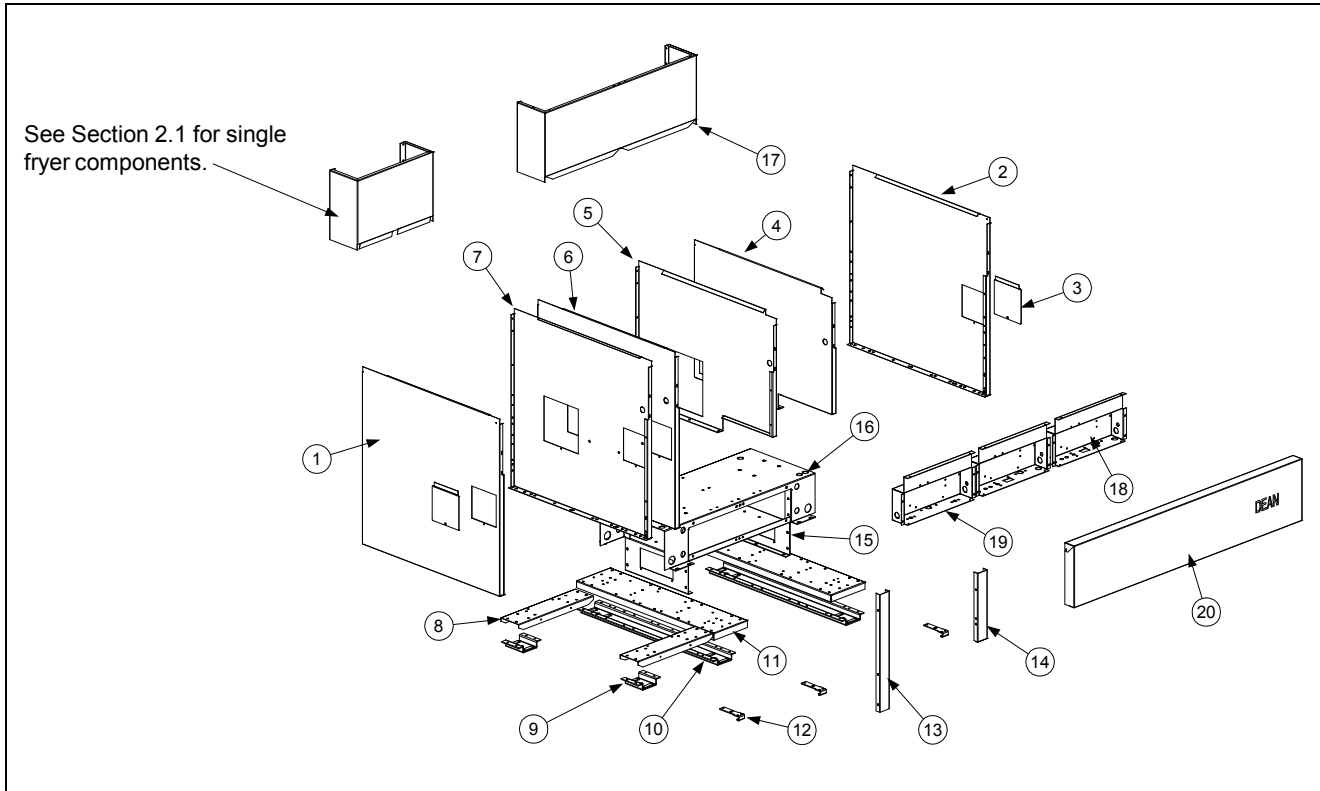

ITEM	PART #	COMPONENT
1	2113261	Side, Left- S/S- (Use When SM20G Is On End)
*	2112787	Side, Left- S/S- (Use When SM50G Is On End)
*	2013369	Side, Left- Painted (Use When SM50G is On End)
2	2123261	Side, Right- S/S- (Use When SM20G Is On End)
*	2122787	Side, Right- S/S- (Use When SM50G Is On End)
*	2023369	Side, Right- Painted (Use When SM50G is On End)
3	2102804	Duct, Door Access- <u>All SM Series Multi-Battery Fryers</u>
4	2022799	Panel, Inner- SUFF Base-Right- <b>SM50G</b>
5	2012799	Panel, Inner- SUFF Base-Left- <b>SM50G</b>
6	2023268	Panel, Inner- Right- <b>SM20G To SM50G</b>
7	2013268	Panel, Inner- Left- <b>SM20G To SM50G</b>
8	2001148	Base Channel, Front & Rear- <b>SM220G, SM50G (See Section 2.1 For Additional Single Fryer Base Channel Components)</b>
*	2003154	Channel, Double- Front & Rear- <b>SM80G Systems (4-Battery)</b>
9	8233248	Support, Leg- <u>All SM 60/80 Series Multi-Battery Fryers With UFF</u>
10	8233539	Support, Leg- <u>All SM 20/50 &amp; 50 Series Multi-Battery Fryers With UFF</u>
11	2002783	Channel, Filter Base- <u>All SM 20/50 Series UFF-Equipped</u>
*	2001198	Channel, Filter Base- <u>All SM60G-80G Series UFF-Equipped</u>
12	2001675	Bracket, Lower Hinge- <u>All SM Series UFF-Equipped</u>
13	2001393	Channel, Lower Joiner- <u>All SM 20/50 &amp; 50 Series Multi-Battery Fryers With UFF</u>
14	2002308	Post, Door- <u>All SM 20/50 &amp; 50 Series Multi-Battery Fryers With UFF</u>

\* Not Illustrated

**FRYMASTER DEAN MILLIVOLT GAS FRYERS  
CHAPTER 2: PARTS LIST**

**2.2 Cabinetry Components, Multi-Battery Frying Systems**

ITEM	PART #	COMPONENT
15	2002830	Base, Filter Frame- Lower- <u>SM 20/50 &amp; 50 Series Multi-Battery Fryers w/ UFF</u>
16	2002785	Base, Filter Frame- Upper- <u>SM 20/50 &amp; 50 Series Multi-Battery Fryers w/ UFF</u>
17	8233634	Fluecap, <b>SM250G</b>
*	8233705	Fluecap, <b>SM20/20/50G</b>
*	8233516	Fluecap, <b>SM260G</b>
*	8233659	Fluecap, <b>SM280G</b>
18	8240995	Wireway, Control Panel- <b>SM50G</b>
*	8240993	Wireway, Control Panel- <b>SM60G</b>
*	8241128	Wireway, Control Panel- <b>SM80G</b>
19	8241025	Wireway, Control Panel- <b>SM220G</b>
*	8241026	Wireway, Control Panel- <b>SM20G</b>
20	8241029	Topcap- <b>SM20/20/50/50G</b>
*	8241030	Topcap- <b>SM20/50/50/20G</b>
*	8241028	Topcap- <b>SM20/20/50G</b>
*	8241177	Topcap- <b>SM20/20/50G 3-Battery</b>
*	8240999	Topcap- <b>SM250G</b>
*	8241000	Topcap- <b>SM350G</b>
*	8241001	Topcap- <b>SM450G</b>
*	2102822	Topcap- <b>SM260G</b>
*	2102824	Topcap- <b>SM360G</b>
*	2102825	Topcap- <b>SM460G</b>
*	8241009	Topcap- <b>SM280G</b>
*	8241010	Topcap- <b>SM380G</b>
*	8241011	Topcap- <b>SM480G</b>
*	2105109	Joiner Strip- <b>SM22G</b>
*	2103182	Joiner Strip- <b>SM50/60, SR62G</b>
*	2101679	Joiner Strip- <b>SM220</b>
*	2102681	Joiner Strip- <b>SR42</b>
*	KIT00092SP	Air Shutter Kit
<b>ACCESSORIES</b>		
*	8030271	Basket, Fry ( <b>SM20, SM40, SM50, SR42 and SR52</b> )
*	8030304	Basket, Fry ( <b>SM60 and SM80</b> )
*	8030277	Screen, Fine Mesh <b>SR42 (Use 803-0149 for SR62, SM60)</b>
*	8030280	Screen, Fine Mesh <b>SM80</b>
*	8030273	Rack, Basket Support <b>SR42</b>
*	8030442	Rack, Basket Support <b>ESG35T</b>
*	8030327	Grid Assembly <b>SM20</b> Basket Rack
*	2103911	Hanger, Basket <b>20/50/MC</b>
*	2103368	Hanger, Basket <b>SM20 (Hooks over the Flue)</b>
*	2101595	Hanger, Basket <b>SM35/40/50 SS 15½"</b>
*	2001360	Hanger, Basket (Over flue style) <b>SR42/52 CR 15½"</b>
*	2102737SP	Hanger, Basket <b>SR62/SM60/SM160G SS 20" (Hooks over Flue)</b>
*	8102793	Hanger, Wire Basket Single <b>SR42/50</b>
*	8102794	Hanger, Wire Basket Double <b>SR42/50/62</b>
*	1062631SP	Tray Assembly, Sediment <b>SM60</b>
*	8090171	Thumbscrew (Nut 826-1351 qty. 10)
*	1061637SP	Frypot Cover <b>SR42/52, SM50</b>
*	1061479SP	Frypot Cover <b>SM60</b>
*	1062470	Frypot Cover <b>SM80</b>

\* Not Illustrated

**FRYMASTER DEAN MILLIVOLT GAS FRYERS**  
**CHAPTER 2: PARTS LIST**

**2.3 Component Box Components and Related Components (CE and Domestic)\***

\* Components are applicable to all Millivolt fryers covered in this manual unless otherwise noted.

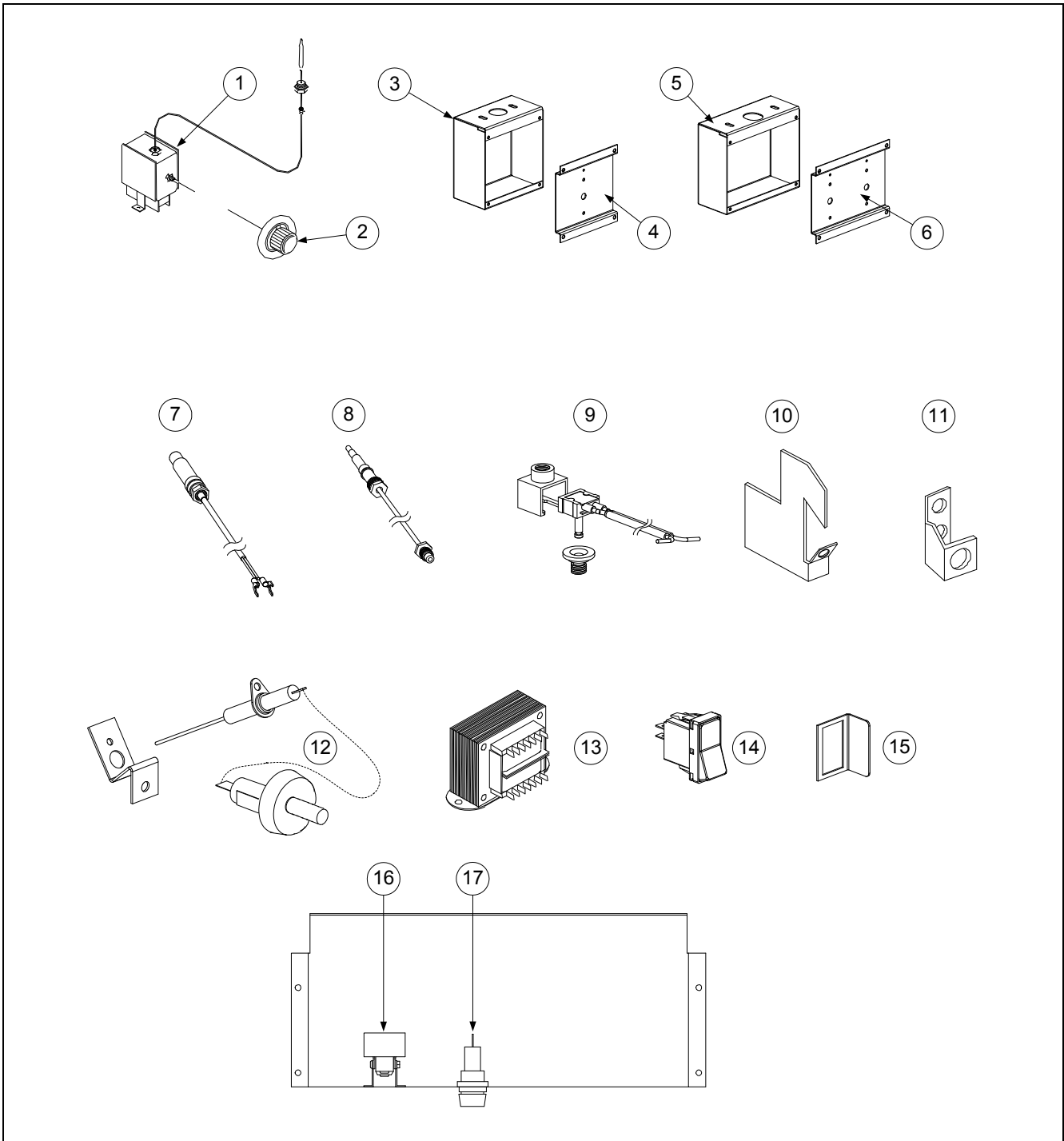

**FRYMASTER DEAN MILLIVOLT GAS FRYERS  
CHAPTER 2: PARTS LIST**

**2.3 Component Box Components and Related Components (CE and Domestic- cont.)**

ITEM	PART #	COMPONENT
1	8262013	Thermostat, Sunne <i>(Use 8071692 for CE)</i>
*	8102047	Spring, Spacer- Thermostat Capillary Bulb
*	2101302	Clamp, Thermostat/High Limit Capillary Bulb <i>(Use 2101433 for 2 hole)</i>
*	2001320	Mounting Bracket, Thermostat & High-Limit
2	8102035	Knob, Thermostat <i>(Use 8160139 for CE)</i>
3	2001618	Box, Thermostat- Single
4	2003217	Cover, Thermostat Box- Single
5	2003277	Box, Thermostat- Dual <i>(Used in 20/50 Combination Systems)</i>
6	2003906	Cover, Thermostat Box- Dual <i>(Used in 20/50 Combination Systems)</i>
7	8102033	Thermopile <i>(Use 8073565 for CE)</i>
8	8101152	Thermocouple <b>(CE ONLY)</b> <i>(Use 8121284 for Assembly)</i>
9	1061768SP	ECO Connector (Honeywell Valves Only- <b>CE ONLY</b> )
*	1061879	ECO Connector (Robertshaw Valves Only- <b>CE ONLY</b> )
10	2005479	Bracket, Pilot Thermocouple
11	8102401	Bracket, Thermopile
12	8101001	Piezo Ignitor (Trigger) <i>(Wire Lead-8073650) (Assembly-44970SP)</i>
*	2001868	Piezo Bracket
*	8073540	Electrode, Piezo CE <i>(Use 8121532 for modified Electrode)</i>
13	8071999	Transformer, Dual Voltage CE- Filtration System <b>(CE ONLY)</b>
*	8070800	Transformer, 120/24 VAC- Filtration System
14	8073580	Switch, Rocker- Manual Filter Power
15	2102786	Guard, Switch (Optional- For Item 10)
16	8073516	High-Limit Thermostat- Automatic Reset 435° F SM20/35,SR40/42
*	8073560	High-Limit Thermostat- Manual Reset 410° F <b>(CE)</b>
*	8073680	High-Limit Thermostat- Manual Reset 450° F
*	8102046	Spring, Spacer- High Limit Capillary Bulb
17	8071321	Fuse Holder, Buss
*	2747	Fuse Holder, Slot-head—Safety <b>(CE ONLY)</b> <i>(obsolete)</i>
*	8073592	Fuse 2A Slow-Blow (230V Systems)
*	8073750	Fuse 5A (120V Systems)

\* Not Illustrated

**FRYMASTER DEAN MILLIVOLT GAS FRYERS  
CHAPTER 2: PARTS LIST**

**2.4 Frypot and Burner System Components**

**2.4.1 SM220 and SM20/20/~ Systems**

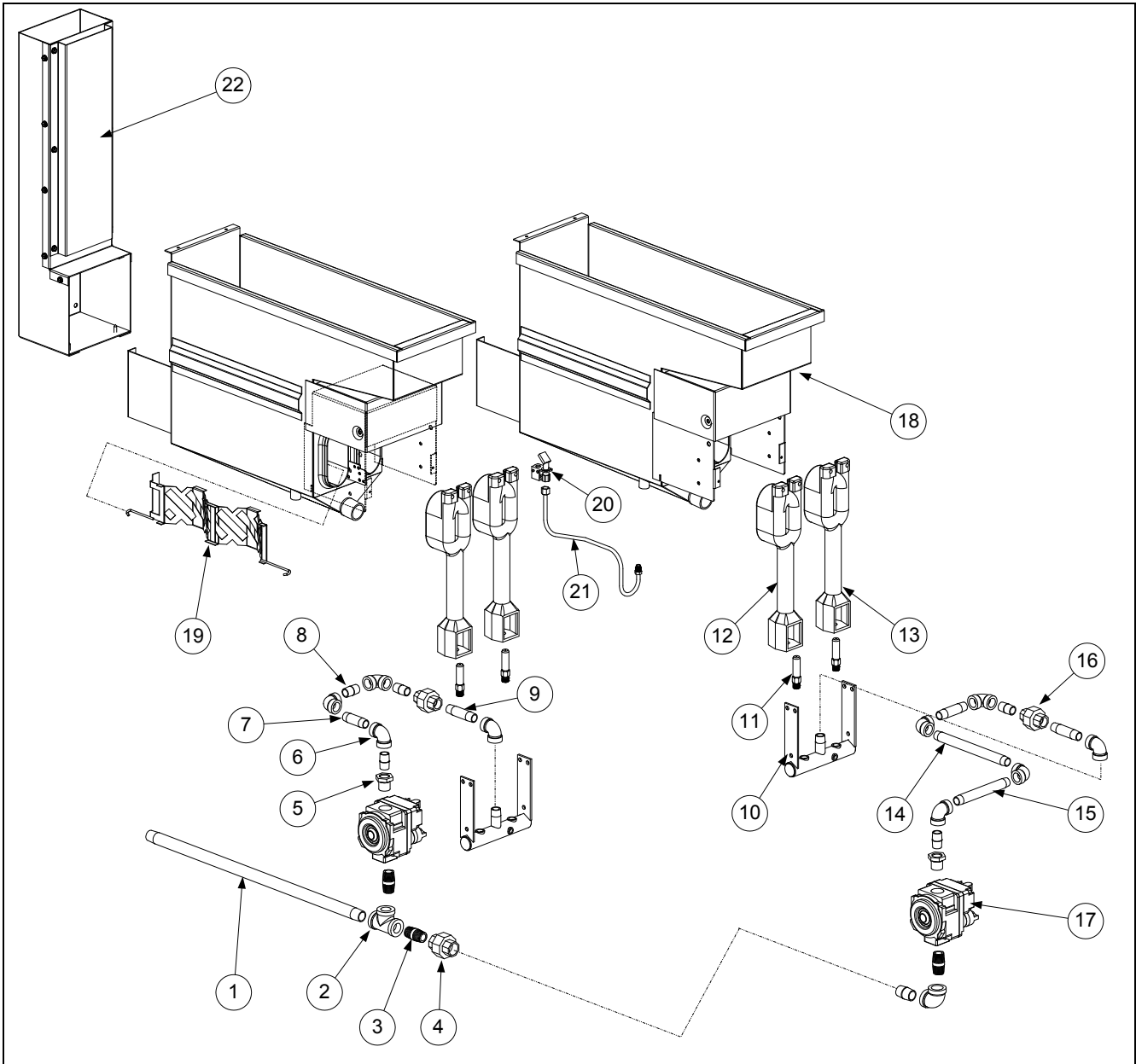

ITEM	PART #	COMPONENT
1	8130737	Nipple, 1/2" NPT x 21" BM
*	8102043	Clamp, Pipe- 1/2" BM Pipe
*	8090805	Bolt, Pipe Clamp- 1/4" -20 x 1/2" Hex
*	2001450	Bracket, Gas-Supply Clamp Support (UFF-Equipped Systems)

\* Not Illustrated

**FRYMASTER DEAN MILLIVOLT GAS FRYERS**  
**CHAPTER 2: PARTS LIST**

**2.4.1 SM220 and SM20/20/~ Systems (cont.)**

ITEM	PART #	COMPONENT
2	8130003	Tee, 1/2" NPT BM
3	8130087	Nipple, 1/2" NPT x 1-1/2" BM
4	8130173	Union, 1/2" NPT BM
5	8130780	Bushing, 3/8" NPT x 1/2" BM
6	8130631	Elbow, 3/8" NPT 90° BM
7	8130676	Nipple, 3/8" NPT x 2" BM
8	8130625	Nipple, 3/8" NPT x Close BM
9	8130649	Nipple, 3/8" NPT x 2-1/2" BM
10	8102352	Manifold, Gas- <b>SM20G</b>
*	2001615	Bracket, Manifold Mounting
11	8102050	Orifice, Natural- #44 (2.18 mm)- <b>Domestic/International</b>
*	8100710	Orifice, LP- #54 (1.40 mm)- <b>Domestic/International</b>
*	8102060	Orifice, G20-G25- (2.40 mm)- <b>CE Only</b>
*	8102059	Orifice, G31- (1.51 mm)- <b>CE Only</b>
12	8102151	Burner, Left
13	8102150	Burner, Right
*	2001374	Bracket, Burner Mounting- <b>SM20G</b>
*	2401391	Bracket, Burner Mounting- <b>SM/D20G CE</b>
*	2001331	Shield, Burner Heat- <b>SM20G</b>
14	8130668	Nipple, 3/8" NPT x 7" BM
15	8130782	Nipple, 3/8" NPT x 5" BM
16	8130781	Union, 3/8" NPT BM
17	8073645	Valve, Gas- Natural (Robertshaw MV) 1/2" in x 3/4" out
*	8071603	Valve, Gas- Natural Honeywell 1/2" in x 1/2" out
*	8102036	Valve, Gas- Natural Honeywell 1/2" in x 3/4" out
*	8072122	Valve, Gas- Natural <b>CE</b> Honeywell
*	8102399	Valve, Gas- Propane (Robertshaw MV)
*	8071604	Valve, Gas- Propane Honeywell
*	8072121	Valve, Gas- Propane <b>CE</b> Honeywell
*	8100975	Knob, Gas Valve Honeywell
*	8100691	Vent Tube 4" (Use 810-1166 for <b>CE</b> 3.86")
18	8261874	Frypot Assembly- <b>SM20G</b> - M/S <i>obsolete use 8261875</i>
*	8261875	Frypot Assembly- <b>SM20G</b> - S/S
19	2005175	Diffuser, Burner-Tube- <b>SM20G</b>
20	8102158	Pilot Burner- <b>SM20G</b> - Natural(0.18 Orifice) ( <b>Use 8102526 for LP</b> )
*	8102689	Pilot Assembly Honeywell w/ Piezo- Natural ( <b>Use 8102690 for LP</b> )
*	1064968	Pilot Assembly w/ Piezo-Natural <b>SM20G</b>
*	1086842	Pilot Assembly w/ Piezo-Natural (0.18 Orifice) <b>SM/D20G CE</b>
21	8100703	Gas Line, Pilot Supply- 1/4" x 17-1/2" (CE -810-1172 - 1/4" x 22")
*	8102602	Gas Line, Pilot Supply- 1/4" x 25"
22	1061583SP	<b>Flue Assembly- SM20G</b>
*	2001342	Shield, Flue Heat- <b>SM20G</b>
*	2001344	Front, Flue Box- <b>SM20G</b>
*	2001351	Rear, Flue Box- <b>SM20G</b>
*	2003081	Air Shutter (Use KIT00092SP for Air Shutter Kit)

\* Not Illustrated

SM 20 series began using Honeywell gas valves in July 2003.

**FRYMASTER DEAN MILLIVOLT GAS FRYERS  
CHAPTER 2: PARTS LIST**

**2.4.2 SR and ESG35T Series, SM35G, SM40G and SM50G Systems**

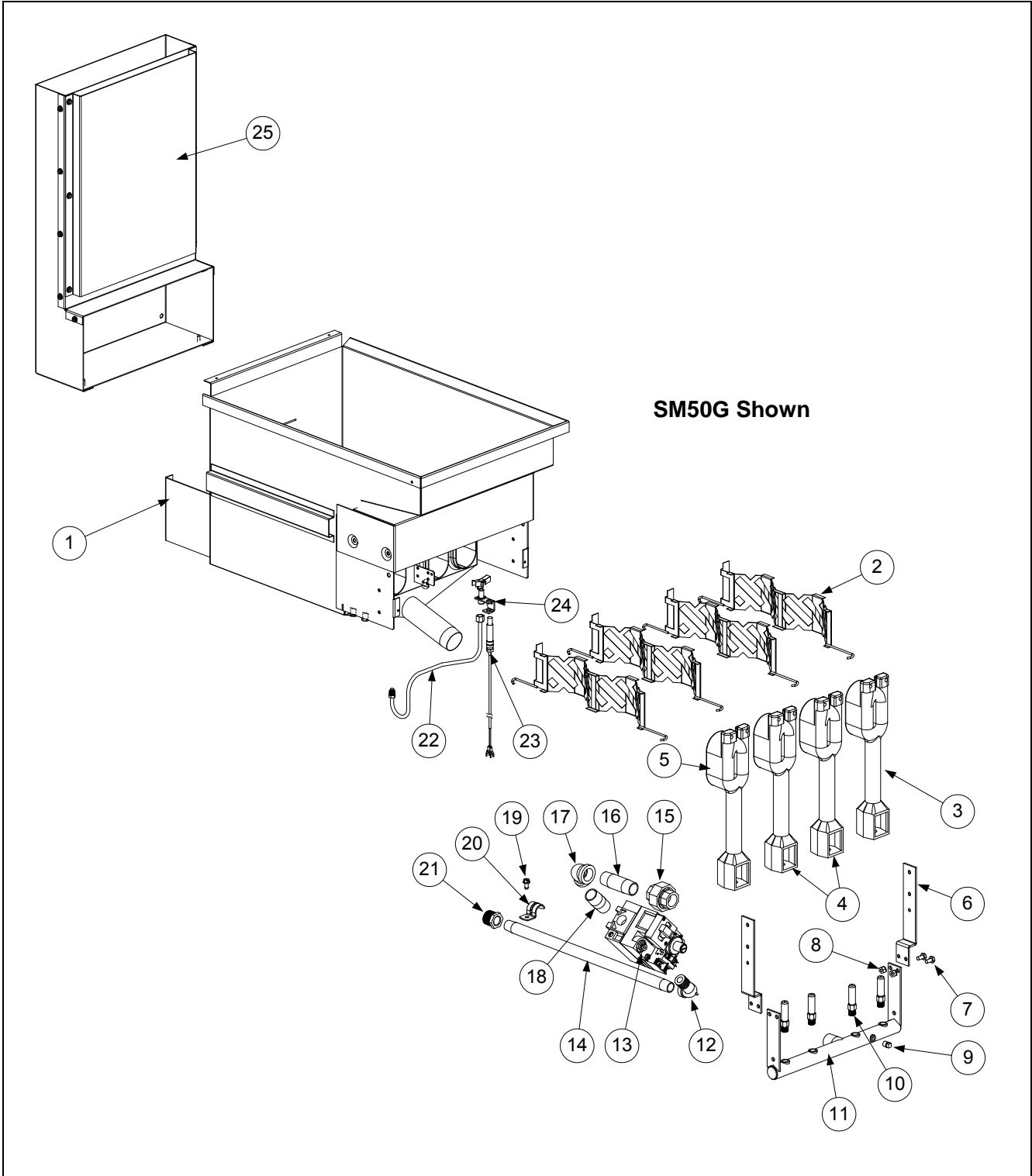

**FRYMASTER DEAN MILLIVOLT GAS FRYERS  
CHAPTER 2: PARTS LIST**

**2.4.2 SR and ESG35T Series, SM35G, SM40G and SM50G Systems (cont.)**

ITEM	PART #	COMPONENT
1	121882	Frypot- S/S (After 6/98)- <b>SR38G</b> (use 12202-2 for Japan/Singapore) <i>obsolete</i>
*	8261865	Frypot- S/S- <b>SR42G</b> ( <i>Began using 1" drain Mar. 2003</i> )
*	8263302	Frypot- S/S- <b>ESG35T</b>
*	8261871	Frypot- S/S- <b>SR52G, SM50G</b>
*	8261867	Frypot- S/S- <b>SM35G, SM40G</b>
2	2105185	Diffuser, Burner Tube- <b>SR38G, SM35G, SM40G</b>
*	2001129	Diffuser, Burner Tube- <b>SR42G</b>
*	2600734	Diffuser, Burner Tube- <b>ESG35T</b>
*	2105175	Diffuser, Burner Tube- <b>SM50G</b>
*	2105216	Diffuser, Burner Tube- <b>SR52G</b>
*	2400666	Shutter, Single Burner- <b>ESG35T</b> Large Shutter
*	2208734	Shutter, Single Burner- <b>ESG35T</b> Small Shutter
3	8102150	Burner, Right- <b>SR52G, SM50G</b>
*	8102039	Burner, Right- <b>SR38G, SR42G, SM35G, SM40G</b>
4	8102149	Burner, Center- <b>SR52G, SM50G</b>
*	8102038	Burner, Center- <b>SR38G, SR42G, SM35G, SM40G</b>
*	8103356	Burner, Universal- <b>ESG35T</b>
5	8102151	Burner, Left- <b>SR52G, SM50G</b>
*	8102037	Burner, Left- <b>SR38G, SR42G, SM35G, SM40G</b>
*	2001329	Bracket, Burner Mounting- <b>SR52G, SM50G</b>
*	8090459	Bolts, Burner <sup>5</sup> / <sub>16</sub> " – 18x <sup>3</sup> / <sub>4</sub> " Hex Head Washer
*	8233600	Support Assy, Burner- <b>SM35G, SM40G</b> (Inc Burner Mtng Brkt & Heat Shld)
*	2001132	Shield, Burner Heat- <b>SR42G</b> <i>not used after 12/10/04</i>
*	2001330	Shield, Burner Heat- <b>SR52G, SM50</b> and 200-1331
6	2001615	Bracket, Manifold Mounting- <b>SR52G, SM50G</b>
*	2001311	Bracket, Manifold Mounting- <b>SR38G, SR42G</b>
*	2400665	Bracket, Manifold Mounting- <b>ESG35T</b>
7	8090428	Bolt, <sup>1</sup> / <sub>4</sub> " -20 x <sup>1</sup> / <sub>2</sub> " Hex Head
8	8090823	Nut, Nylock- <sup>1</sup> / <sub>4</sub> " -20
9	8130705	Plug, Brass- <sup>1</sup> / <sub>8</sub> " Square Head
10		<b>Orifice- Domestic/International</b>
*	8102048	Orifice, Natural- #39 (2.53 mm)- <b>SR52G, SM50G,</b>
*	8102132	Orifice, Natural- #37 (2.64 mm)- <b>SR38G</b>
*	8102040	Orifice, Natural- #35 (2.80 mm)- <b>SR42G, SM35G, SM40G</b>
*	8103097	Orifice, Natural- #35 (2.80 mm) .125- <sup>1</sup> / <sub>8</sub> NPT- <b>SR42G 4/07-11/13</b>
*	8103360	Orifice, Natural- #35 (2.80 mm) <sup>1</sup> / <sub>8</sub> NPT- <b>SR42G after 11/13</b>
*	8104389	Orifice, Natural- #44 (2.18 mm) <sup>1</sup> / <sub>8</sub> NPT – <b>ESG35T</b> (0-1999 Ft, 0-609 M)
*	8104451	Orifice, NG- #45 (2.08 mm) <sup>1</sup> / <sub>8</sub> NPT– <b>ESG35T</b> (2000-3999 Ft, 610-1219M)
*	8104452	Orifice, Natural- #46 (2.06 mm) <sup>1</sup> / <sub>8</sub> NPT – <b>ESG35T</b> (>4000 Ft, >1219 M)
*	8102497	Orifice, LP- #55 (1.32 mm)- <b>SR52G, SR62G, SM20G, SM50G</b>
*	8104456	Orifice, LP- (1.35 mm) <sup>1</sup> / <sub>8</sub> NPT- <b>ESG35T</b> (2000-3999 Ft, 610-1219 M)
*	8103529	Orifice, LP- #54 (1.40 mm) <sup>1</sup> / <sub>8</sub> NPT - <b>ESG35T</b> (0-1999 Ft, 0-609 M)
*	8102059	Orifice, LP- #53 (1.51 mm)- <b>SR52G, SM50G,</b>
*	8103102	Orifice, LP- #53 (1.51 mm) .125- <sup>1</sup> / <sub>8</sub> NPT - <b>SR42 after 4/07</b>
*	8102063	Orifice, LP- #52 (1.61 mm)- <b>SR38G</b>
*	8102064	Orifice, LP- #51 (1.70 mm)- <b>SR42G, SM35G, SM40G</b>
*	8103099	Orifice, LP- #51 (1.70 mm), .125- <sup>1</sup> / <sub>8</sub> NPT - <b>SR42G 4/07-11/13</b>
*	8103361	Orifice, LP- #51 (1.70 mm), <sup>1</sup> / <sub>8</sub> NPT - <b>SR42G after 11/13</b>
*	8102400	Orifice, LP- #16 (.016)- Pilot <b>SR52</b>
*		<b>Orifice- CE Only</b>
*	8102060	Orifice, G20-G25- (2.40 mm)- <u>All Millivolt Fryers in This Section</u>
*	8103101	Orifice, G20-G25- (2.40 mm) .125- <sup>1</sup> / <sub>8</sub> NPT - <b>SR42 built after 4/07</b>

\* Not Illustrated

**FRYMASTER DEAN MILLIVOLT GAS FRYERS  
CHAPTER 2: PARTS LIST**

**2.4.2 SR and ESG35T Series, SM35G, SM40G and SM50G Systems (cont.)**

ITEM	PART #	COMPONENT
*	8102059	Orifice, G31- (1.51 mm)- <u>All Millivolt Fryers in This Section</u>
*	8103102	Orifice, G31- (1.51 mm) .125- $\frac{1}{8}$ " NPT- <b>SR42 built after 4/07</b>
11	8233618	Manifold, Gas- <b>SR52G, SM50G</b>
*	8102034	Manifold, Gas- <b>SR38G, SR42G</b>
*	8103006	Manifold, Gas- <b>SR42G after 4/07, ESG35T</b>
*	8233619	Manifold, Gas- <b>SM35G, SM40G</b>
<b>Gas Valve and Related Plumbing- SM50G – Plumbing Will Vary From Model to Model- Use the Following Parts As A Reference When Obtaining Parts For Systems in This Section Other Than SM50G</b>		
12	8130165	Elbow, Street- $\frac{1}{2}$ " NPT 90° BM
13	8102036	Valve, Gas- Natural, Honeywell- <b>Domestic/International</b> $\frac{1}{2}$ " in x $\frac{3}{4}$ " out
*	8071603	Valve, Gas- Natural, Honeywell- $\frac{1}{2}$ " in x $\frac{1}{2}$ " out Started using Feb. 2003
*	8073648	Valve, Gas- Natural, Honeywell- $\frac{3}{4}$ " in x $\frac{3}{4}$ " out Started using Feb. 2003 Export
*	8073645	Valve, Gas- Natural, Robertshaw- $\frac{1}{2}$ " in x $\frac{3}{4}$ " out
*	8073549	Valve, Gas- LP, Honeywell- <b>Domestic/International</b>
*	8071604	Valve, Gas- LP, Honeywell- $\frac{1}{2}$ " in x $\frac{1}{2}$ " out Started using Feb. 2003
*	8073553	Valve, Gas- LP, Honeywell- $\frac{3}{4}$ " in x $\frac{3}{4}$ " out
*	8101155	CE Adaptor Kit, Honeywell Valve
*	8072122	Valve, Gas- Natural, Honeywell- <b>CE Only</b>
*	8072121	Valve, Gas- LP, Honeywell- <b>CE Only</b>
*	8074137	Valve, Gas- Natural, Honeywell- <b>Australia</b>
*	8074138	Valve, Gas- LP, Honeywell- <b>Australia</b>
*	8071846	Valve, Kit – Natural to Propane Conversion
14	8130418	Nipple, $\frac{1}{2}$ " NPT x 17" BM- <b>SM50G</b>
*	8130670	Nipple, $\frac{1}{2}$ " NPT x 19" BM ( <u>Measure To Confirm Length</u> )
*	8130585	Nipple, $\frac{1}{2}$ " NPT x 20- $\frac{1}{2}$ " BM ( <u>Measure To Confirm Length</u> )
*	8130737	Nipple, $\frac{1}{2}$ " NPT x 21" BM ( <u>Measure To Confirm Length</u> )
15	8130174	Union- $\frac{3}{4}$ " NPT BM
16	8130254	Nipple, $\frac{3}{4}$ " NPT x 3" BM- <b>SM50G</b>
17	8130066	Elbow- $\frac{3}{4}$ " NPT 90° BM
18	8130112	Nipple, $\frac{3}{4}$ " NPT x 2" BM- <b>SM50G</b>
19	8090805	Bolt, $\frac{1}{4}$ "-20 x $\frac{1}{2}$ " Hex Head
20	8102043	Clamp, Pipe- $\frac{1}{2}$ "
*	2001450	Bracket, Gas-Supply Clamp Support (UFF-Equipped Systems)
21	8130031	Bushing, $\frac{3}{4}$ " NPT x $\frac{1}{2}$ " NPT BM
22	8100703	Gas Line, Pilot Supply- $\frac{1}{4}$ " x 17- $\frac{1}{2}$ " (For <b>CE</b> use 8101172 <b>23"</b> or 8102602 <b>25"</b> )
23	8102033	Thermopile- Non-CE
*	8073565	Thermopile- <b>CE Only</b> ( Thermocouple 810-1152)
24	8102032	Burner, Pilot- Natural (Use 1060692SP for Assembly. Includes item 22, 23 and 24)
*	8102155	Burner, Pilot- LP
25	1061742SP	<b>Flue Assembly- SR52G, SM50G</b>
*	2002872	Shield, Flue Heat- <b>SR52G, SM50G</b>
*	2001343	Front, Flue Box- <b>SR52G, SM50G</b>
*	2001350	Rear, Flue Box- <b>SR52G, SM50G</b>
*	12203	<b>Flue Assembly- SR38G</b>
*	120363	Shield, Flue Heat- <b>SR38G obsolete</b>
*	120362	Front, Flue Box- <b>SR38G obsolete</b>
*	120361	Rear, Flue Box- <b>SR38G obsolete</b>
*	1060696SP	<b>Flue Assembly- SR42G</b>
*	2001304	Front, Flue Box- <b>SR42G</b>
*	2001303	Rear, Flue Box- <b>SR42G</b>

\* Not Illustrated

## FRYMASTER DEAN MILLIVOLT GAS FRYERS CHAPTER 2: PARTS LIST

### 2.4.2 SR and ESG35T Series, SM35G, SM40G and SM50G Systems (cont.)

ITEM	PART #	COMPONENT
*	1085670	<b>Flue Assembly- ESG35T</b>
*	2400669	Front, Flue Box- <b>ESG35T</b>
*	2400670	Rear, Flue Box- <b>ESG35T</b>
*	1060954SP	<b>Flue Assembly- SM35G, SM40G</b>
*	2001690	Shield, Flue Heat- <b>SM35G</b>
*	2001701	Front, Flue Box- <b>SM35G</b>
*	2001678	Rear, Flue Box- <b>SM35G</b>
*	44941001	Garland SM50 Drop In Assembly- Natural
*	4494100001	Garland SM50 Drop In Assembly- Propane

\* Not Illustrated

### 2.4.3 SR62, SM60G and SM80G Systems

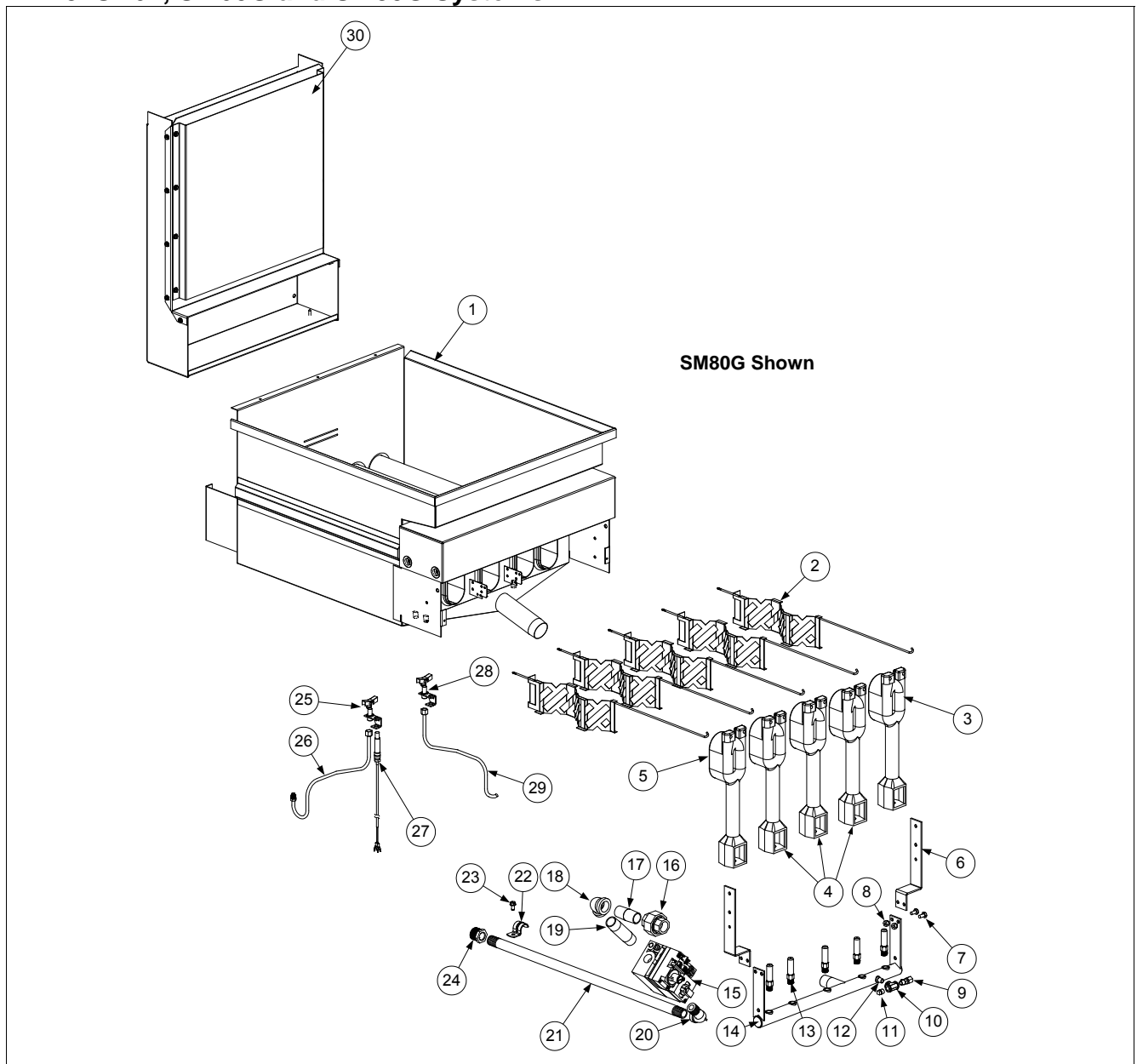

**FRYMASTER DEAN MILLIVOLT GAS FRYERS  
CHAPTER 2: PARTS LIST**

**2.4.3 SR62, SM60G and SM80G Systems (cont.)**

ITEM	PART #	COMPONENT
1	8233494SP	Frypot- S/S- <b>SM80G (After 10/99) 1¼"</b> (Use 8233396SP for 1 ½")
*	8261891	Frypot- S/S- <b>SM80G (Prior To 10/99)</b>
*	8261802	Frypot- S/S- <b>SM60G, SR62G (Use 8233511SP for SM160G)</b>
2	8233404	Diffuser, Burner Tube- <b>SM80G</b>
*	2105215	Diffuser, Burner Tube- <b>SM60G, SR62G</b>
3	8102150	Burner, Right- <b>SM60G, SM80G, SR62G</b>
4	8102149	Burner, Center- <b>SM60G, SM80G, SR62G</b>
5	8102151	Burner, Left- <b>SM60G, SM80G, SR62G</b>
*	2002734	Bracket, Burner Mounting- <b>SM80G</b>
*	2002738	Bracket, Burner Mounting- <b>SM60G, SR62G</b>
*	2002707	Shield, Burner Heat- <b>SM80G</b>
*	2002746	Shield, Burner Heat- <b>SM60G, SR62G</b>
6	2001314	Bracket, Manifold Mounting- <b>SM80G</b>
*	2001615	Bracket, Manifold Mounting- <b>SM60G, SR62G</b>
7	8090428	Bolt, ¼"-20 x ½" Hex Head
8	8090823	Nut, Nylock- ¼"-20
9	8102138	Valve, Trailing Pilot- <b>SM60G, SM80G, SR62G adjustment valve</b>
10	8130642	Tee, ⅛" NPT
11	8130705	Plug, Brass- ⅛" Square Head
12	8130643	Nipple, ⅛" NPT x Close BM
13		<b>Orifice- Domestic/International</b>
*	8102062	Orifice, Natural- #38 (2.58 mm)- <b>SM80G</b>
*	8102048	Orifice, Natural- #39 (2.53 mm)- <b>SM60G, SR62G</b>
*	8102063	Orifice, LP- #52 (1.61 mm)- <b>SM80G, SR62G (Australia)</b>
*	8102059	Orifice, LP- #53 (1.51 mm)- <b>SM60G, SR62G</b>
*		<b>Orifice- CE Only</b>
*	8102060	Orifice, G20-G25- (2.40 mm)- <u>All Millivolt Fryers in This Section</u>
*	8102059	Orifice, G31- (1.51 mm)- <u>All Millivolt Fryers in This Section</u>
14	8233617	Manifold, Gas- <b>SM60G, SM80G, SR62G</b>
15	8102036	Valve, Gas- Natural, Honeywell- <b>Domestic/Intl ½" in x ¾" out</b>
*	8072122	Valve, Gas- Natural, Honeywell- <b>CE Only</b>
*	8073648	Valve, Gas- Natural and MFG, Honeywell ¾" in x ¾" out (Export)
*	8073645	Valve, Gas- Natural, Robertshaw MV ½" in x ¾" out
*	8073549	Valve, Gas- LP, Honeywell- <b>Domestic/Intl</b>
*	8072121	Valve, Gas- LP, Honeywell- <b>CE Only</b>
*	8102399	Valve, Gas- LP, Robertshaw MV
16	8130174	Union- ¾" NPT BM
17	8130635	Nipple, ¾" NPT x 2-½" BM
18	8130066	Elbow- ¾" NPT 90° BM
19	8130743	Nipple, ¾" NPT x 3-½" BM
20	8130165	Elbow, Street- ½" NPT 90° BM
21	8130670	Nipple, ½" NPT x 19" BM ( <u>Measure To Confirm Length</u> )
*	8130585	Nipple, ½" NPT x 20-½" BM ( <u>Measure To Confirm Length</u> )
*	8130737	Nipple, ½" NPT x 21" BM ( <u>Measure To Confirm Length</u> )

\* Not Illustrated

**FRYMASTER DEAN MILLIVOLT GAS FRYERS  
CHAPTER 2: PARTS LIST**

**2.4.3 SR62, SM60G and SM80G Systems (cont.)**

<b>ITEM</b>	<b>PART #</b>	<b>COMPONENT</b>
22	8102043	Clamp, Pipe- 1/2"
23	8090805	Bolt, Pipe Clamp- 1/4"-20 x 1/2" Hex
*	2001450	Bracket, Gas-Supply Clamp Support (UFF-Equipped Systems)
24	8130031	Bushing, 3/4" NPT x 1/2" NPT BM
25	8102032	Burner, Pilot- Natural <i>(Use 1060692SP for Assembly)</i>
*	8102155	Burner, Pilot- LP <i>(Use 1061696SP for Assembly)</i>
26	8100703	Gas Line, Main Pilot Supply- 1/4" x 17-1/2"
*	8101172	Gas Line, Pilot Supply- 1/4" x 23" <b>CE</b>
*	8102602	Gas Line, Pilot Supply- 1/4" x 25" <b>CE</b>
27	8102033	Thermopile- Non-CE
*	8073565	Thermopile- <b>CE Only</b>
28	8102032	Burner, Pilot- Natural & MFG (Also Used For Main Pilot)
*	1060692	Burner, Pilot Assembly- Natural & MFG
*	8102155	Burner, Pilot- LP (Also Used For Main Pilot)
29	8120703	Gas Line, Trailing Pilot Supply- 1/4" x 17-1/2" (Cut To Length)
30	1061442SP	<b>Flue Assembly- SM80G</b>
*	2001316	Shield, Flue Heat- <b>SM80G</b>
*	2001347	Front, Flue Box- <b>SM80G</b>
*	2001349	Rear, Flue Box- <b>SM80G</b>
*	1060997SP	<b>Flue Assembly- SM60G, SR62G</b>
*	2001325	Shield, Flue Heat- <b>SM60G, SR62G</b>
*	2001339	Front, Flue Box- <b>SM60G, SR62G</b>
*	2001773	Rear, Flue Box- <b>SM60G, SR62G</b>

\* Not Illustrated

**FRYMASTER DEAN MILLIVOLT GAS FRYERS**  
**CHAPTER 2: PARTS LIST**

**2.5 Oil Drain Manifold Components**

**2.5.1 1½” Oil Drain Manifold, Drain Flush and Drain Valve Components\***

\*Typical components illustrated below. Components will vary according to system.

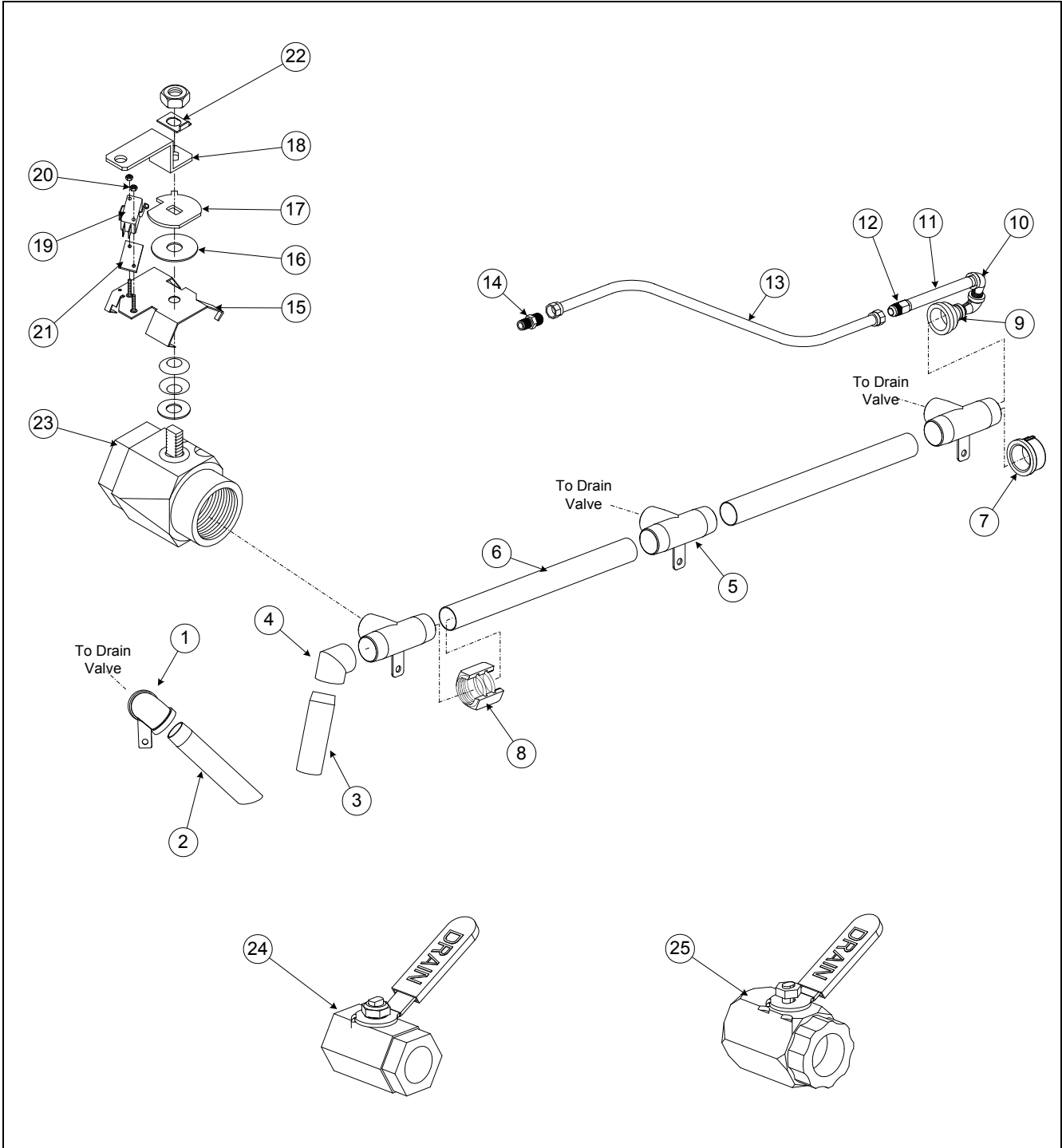

**FRYMASTER DEAN MILLIVOLT GAS FRYERS**  
**CHAPTER 2: PARTS LIST**

**2.5.1 Oil Drain Manifold, Drain Flush and Drain Valve Components (cont.)**

ITEM	PART #	COMPONENT
1	8233565	Elbow, with Bracket (LH)- 1-¼"- UFF 50
*	8233566	Elbow, with Bracket (RH)- 1-¼"- UFF 50
2	8121524	Drain Pipe, Left Side (Use 823-3418 for Chili's)
3	8130784	Drain Pipe, Right Side 1 ½" x 6"
4	8130829	Elbow, 1-½" NPT 75°
5	8130748	Tee, 1-½" NPT x 1-¼" BM With Handle Bracket
6	2001827	Drain Manifold Tube- 1-½" x 13-¼"
7	8130659	Pipe Cap, 1-½"
8	8090884	Nut, Slip Joint- 1-½"
*	8160544	O-ring (Slip-Joint Nut)
9	8130686	Bell Reducer, ½" NPT x 1-½"
10	8130165	Elbow, Street- ½" NPT 90°
11	8130672	Nipple, ½" NPT x 8" BM
12	8101669	Adapter, ⅝" O.D. x ½"- Female
13	8101069	Flex Line, ⅝" x 29-½"
14	8101668	Adapter, ⅝" O.D. x ½"- Male
<b>Drain Valve Components</b>		
15	1061401	Bracket, Microswitch (Optional On SUFF/UFF Units)
16	2001617	Washer, Drain Valve (Use Without Microswitch)
17	2102029	Bracket, Activator- Microswitch (Also Used On Valves Without Microswitch As A Handle-Stop)
18	2104727	Handle (Actuator), Drain Valve
*	8233440	Handle, Push/Pull- Drain (With Cap)
*	8090885	Washer, ⅜" x 1" x .083"
*	8090843	Pin, Cotter
*	8160547	Cap, Vinyl-Red
19	8072104	Microswitch (Optional On SUFF/UFF Units)
20	8090842	Nut, Nylock- #4-40 (Microswitch To Bracket)
21	8160220	Insulation, Microswitch
22	2001257	Retainer, Nut
23	8102127	Drain Valve, 1-½" Full Port (With Washers & Nut)
24	8102052	Drain Valve, 1-¼" (1" Standard Port)
*	8102442	Handle, Valve Lever
*	8101338	Drain Valve, 1" <b>SM20G, SR42G, ESG35T</b> <i>see note below</i>
*	2103902	Handle, Valve Lever ( <b>For 8101338 Only</b> )- <b>SM20G</b>
*	1061417SP	Drain Valve Assembly 1" RH and LH
*	8130138	Nipple, 1" NPT x Close (To Adapt To 1-¼" Extended Drain Nipple)
*	8130716	Bushing, 1" NPT x 1-¼" BM (To Adapt To 1-¼" Extended Drain Nipple)
*	8130406	Coupling, 1-¼" NPT x 2" (To Adapt To 1-¼" Extended Drain Nipple)
25	8102126	Drain Valve, 1-¼" Full-Port (Use 106-2439 for Assembly)
*	8121226SP	Nipple, Drain- 1-¼" Painted- <b>SM Series Fryers (use 8130276 for SM20)</b>
*	8130392	Nipple, Drain- 1-¼" NPT x 8" BM- <b>All SR Series Fryers except SR42 w/ 1"</b>
*	8121681	Nipple, Drain- 1-¼" x 5" NPT
*	8130870	Nipple, Drain- 1-¼" x 10" NPT
*	8130669	Nipple, Drain- 1" x 8" (Use 8121668 for 5"- <b>SR42</b> ) (Use 8130605 for 9"- <b>SR62</b> )

\* Not Illustrated

Note: In Mar. 2003 SR42G went to 1" drain valves.

**FRYMASTER DEAN MILLIVOLT GAS FRYERS  
CHAPTER 2: PARTS LIST**

**2.5.2 3" Oil Drain Manifold, Drain Flush and Drain Valve Components**

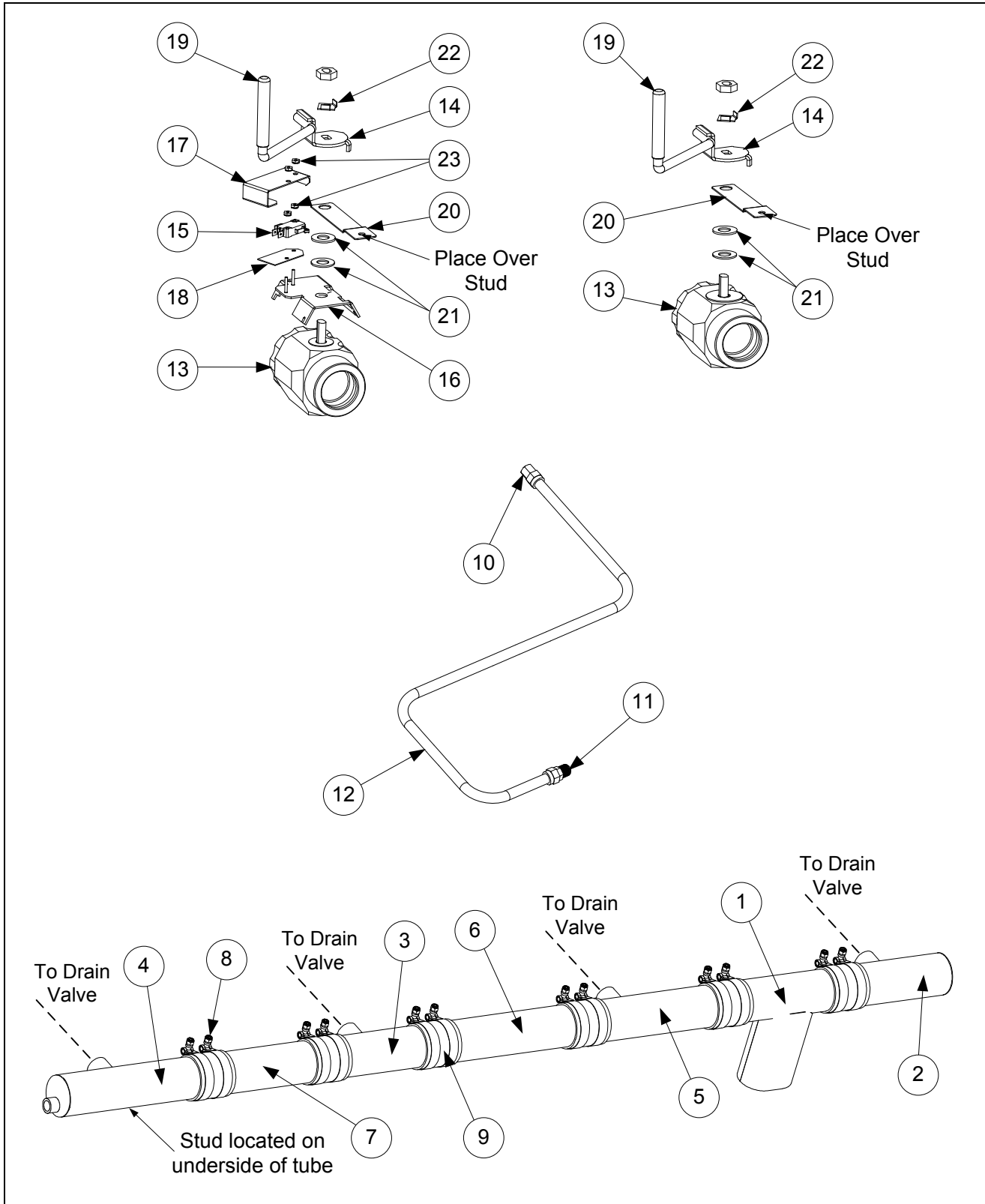

**FRYMASTER DEAN MILLIVOLT GAS FRYERS  
CHAPTER 2: PARTS LIST**

**2.5.2 3" Oil Drain Manifold, Drain Flush & Drain Valve Components (cont.)**

<b>ITEM</b>	<b>PART #</b>	<b>COMPONENT</b>
1	8234712	Tube, 3" Oval Dump
2	8234681	Tube, 3" Right Drain (closed end)
3	8234682	Tube, 3" Center Drain (open ends)
4	8234844	Tube, 3" Left Drain (closed end)
5	8235188	Tube, 3" Right Filter (open ends)
6	2006603	Tube, 3" Joiner (11.5")
7	2009365	Tube, 3" Joiner (8.63")
8	8090969	Clamp, T-bolt
9	8160625	Boot/Sleeve
	1061726	<b>Flush Oil Drain Line</b>
10	8101669	Adapter, Female 5/8" O.D. x 1/2" long
11	8101668	Adapter, Male 5/8" O.D. x 1/2" long
12	8101056	Flexline, 5/8" O.D. x 52.5" long
	1063976	<b>Drain Valve Assembly, 1 1/2" Without Microswitch</b>
	1063977	<b>Drain Valve Assembly, 1 1/2" With Microswitch</b>
13	8102783	Drain Valve, 1 1/2" Full Port with O-ring
14	8234734	Handle, Drain Valve Rotating
15	8072104	Microswitch, CE Micro-roller Lever
16	1061401	Microswitch Bracket Assembly
17	2004402	Guard, Drain Microswitch
18	8160220	Insulation, RF Switch
19	8160547	Cap, Red Vinyl for Handle
20	2006116	Strap, 1 1/2" (holds tube to valve via the stud)
21	2001617	Washer, Drain Microswitch
22	2001257	Retainer, Drain Valve
23	8261366	Nut, 4-40 Keps Hex w/ External Teeth (Pkg. of 25)
*	8160630	Cap, Vinyl (one per clamp, covers T-bolt threads)

\* Not Illustrated

**FRYMASTER DEAN MILLIVOLT GAS FRYERS  
CHAPTER 2: PARTS LIST**

**2.6 Oil Return Manifold Components**

**2.6.1 Oil Return Manifold Components; Fryers with 1½" Drains\***

\*Typical components illustrated below. Components will vary according to system.

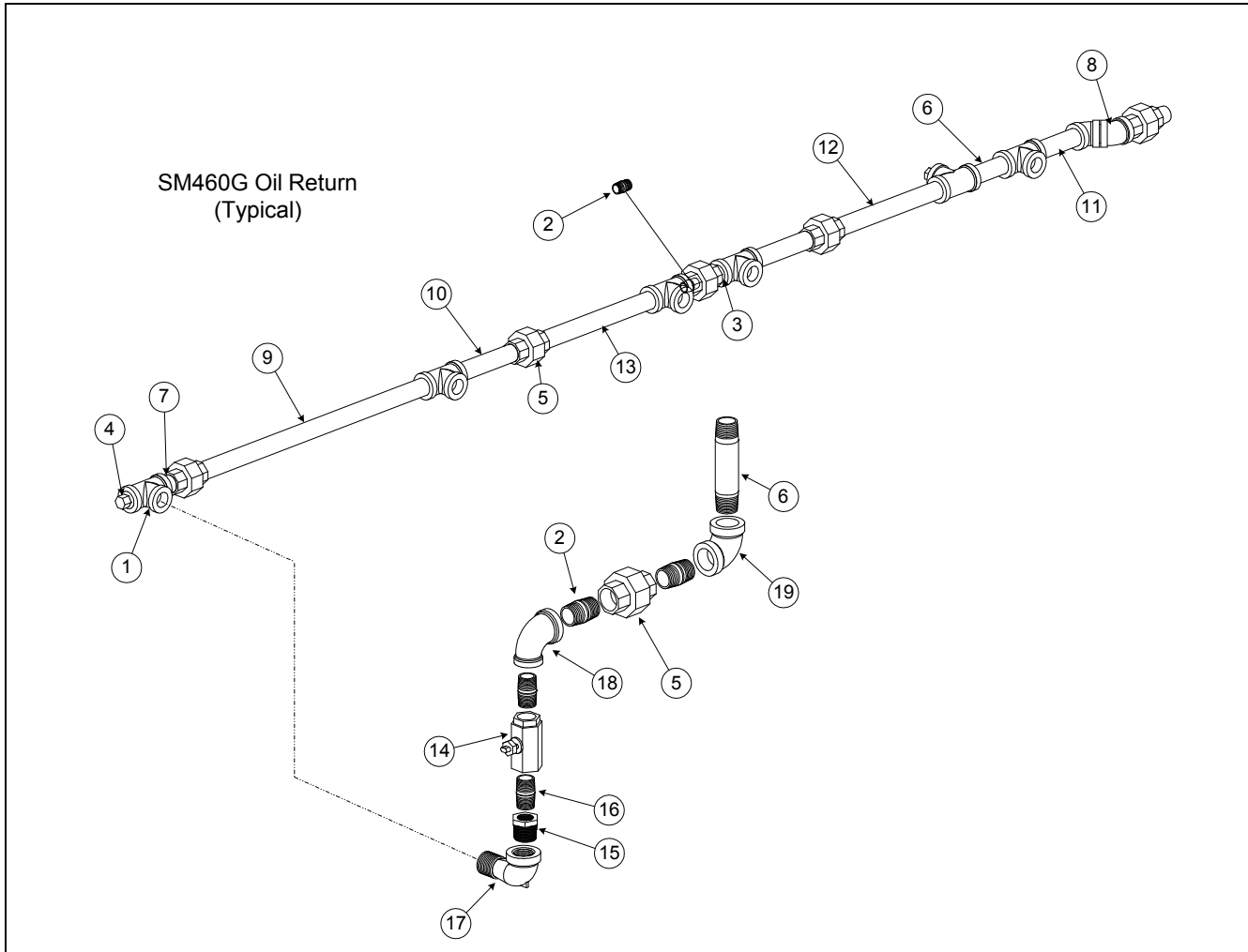

ITEM	PART #	COMPONENT
1	8130003	Tee, ½" x ½" x ½" BM
2	8130022	Nipple, ½" x Close NPT BM
3	8130087	Nipple, ½" x 1-½" NPT BM
4	8130156	Plug, ½" NPT Hex Head BM
5	8130173	Union, ½" NPT BM
6	8130247	Nipple, ½" x 3-½" NPT BM
7	8130298	Nipple, ½" x 2" NPT BM
8	8130345	Elbow, ½"- 45°
9	8130368	Nipple, ½" x 16" NPT BM
10	8130646	Nipple, ½" x 5" NPT BM
11	8130654	Nipple, ½" x 4" NPT BM
12	8130672	Nipple, ½" x 8" NPT BM

**FRYMASTER DEAN MILLIVOLT GAS FRYERS  
CHAPTER 2: PARTS LIST**

**2.6.1 Oil Return Manifold Components; Fryers with 1½” Drains (cont.)**

ITEM	PART #	COMPONENT
13	8130673	Nipple, ½” x 8-½” NPT BM
14	8102125	Oil Return Valve, ¾”
*	8100051	Coupling, ½” NPT x 1- <sup>7</sup> / <sub>16</sub> ” to adapt return hose to valve
*	2001143	Retainer, Oil Return Valve Nut
*	8090877	Nut, Oil Return Valve
15	8130006	Bushing, Hex- ½” x ¾” NPT BM
16	8130625	Nipple, ¾” x Close NPT BM
17	8130165	Elbow, Street- ½” x ½” NPT 90° BM
18	8130634	Elbow, ½” x ¾” NPT 90° BM
19	8130062	Elbow, ½” NPT 90° BM
*	1062568SP	Wash Down Hose and Nozzle Assembly

\* Not Illustrated

**FRYMASTER DEAN MILLIVOLT GAS FRYERS  
CHAPTER 2: PARTS LIST**

**2.6.2 Oil Return Manifold Components; Fryers with 3" Drains**

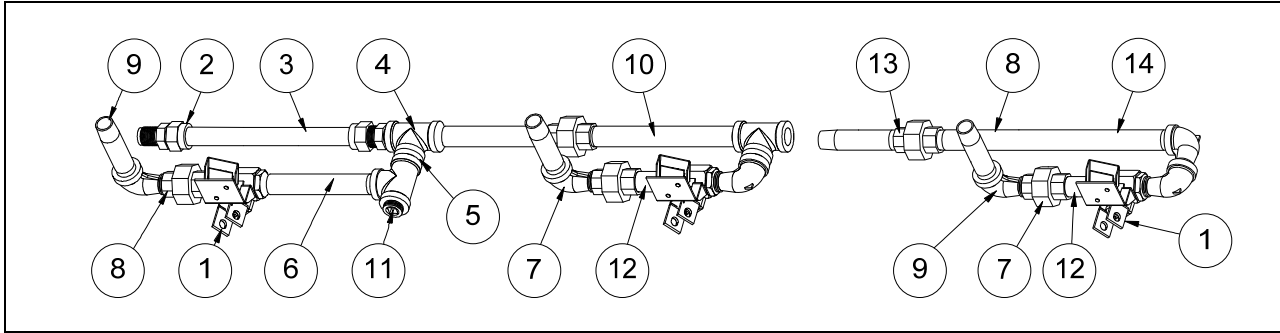

ITEM	PART #	COMPONENT
	1064100	Oil Return Assembly – Middle
	1064101	Oil Return Assembly – End
1	1064006	Valve Assembly, 1/2" Oil Return (see Page 2-25)
*	1063997	Valve Assembly (use with wand)
*	1065516	Valve Assembly, 3-way Oil Return
2	8101668	Adapter, Male 5/8" OD x 1/2"
3	8102320	Flexline, 5/8" x 9.00" Long
4	8130003	Tee, 1/2" x 1/2" x 1/2" BM
5	8130022	Nipple, 1/2" x Close NPT BM
6	8130096	Nipple, 1/2" x 6.00" NPT BM
7	8130165	Elbow, Street 1/2" x 1/2" NPT 90° BM
8	8130173	Union, 1/2" NPT
9	8130247	Nipple, 1/2" x 3.50" NPT BM
10	8130362	Nipple, 1/2" NPT x 7.50" BM
11	8130463	Plug, 1/2" Counter Sink
12	8130661	Nipple, 1/2" x 2.25" NPT BM
13	8130654	Nipple, 1/2" x 4.00" NPT BM
14	8130597	Nipple, 1/2" x 11.50" NPT BM
*	8102125	Ball Valve, 3/8" Drain
*	8130006	Bushing, 1/2" to 3/8" NPT BM Hex Reducing
*	8130062	Elbow, 1/2" 90° BM
*	8101067	Flexline, 8.50" Oil Return
*	8130087	Nipple, 1/2" x 1.50" NPT BM
*	8130460	Nipple, 1/2" x 3.00" NPT BM
*	8130625	Nipple, 3/8" NPT x CL Black CLS
*	8130672	Nipple, 1/2" x 8.00" NPT BM
*	8130607	Nipple, 1/2" x 23.50" NPT BM
*	8130099	Nipple, 1/2" x 7.00" NPT BM
*	8130845	Nipple, 1/2" x 29.75" NPT BM
*	8130646	Nipple, 1/2" x 5.00" NPT BM
*	8130373	Nipple, 1/2" x 11.00" NPT BM
*	8130298	Nipple, 1/2" x 2.00" NPT BM
*	8130098	Nipple, 1/2" x 6.50" NPT BM
*	8130742	Nipple, 1/2" x 5.50" NPT BM
*	8130515	Nipple, 1/2" x 12.00" NPT BM
*	8130265	Nipple, 1/2" x 2.50" NPT BM
*	8130093	Nipple, 1/2" x 4.00" NPT BM

\* Not Illustrated

**FRYMASTER DEAN MILLIVOLT GAS FRYERS  
CHAPTER 2: PARTS LIST**

**2.7 Oil Return and Oil Flush Components**

**2.7.1 Oil Return and Oil Flush Components; Fryers with 1½” Drains\***

\*Typical components illustrated below. Components will vary according to system.

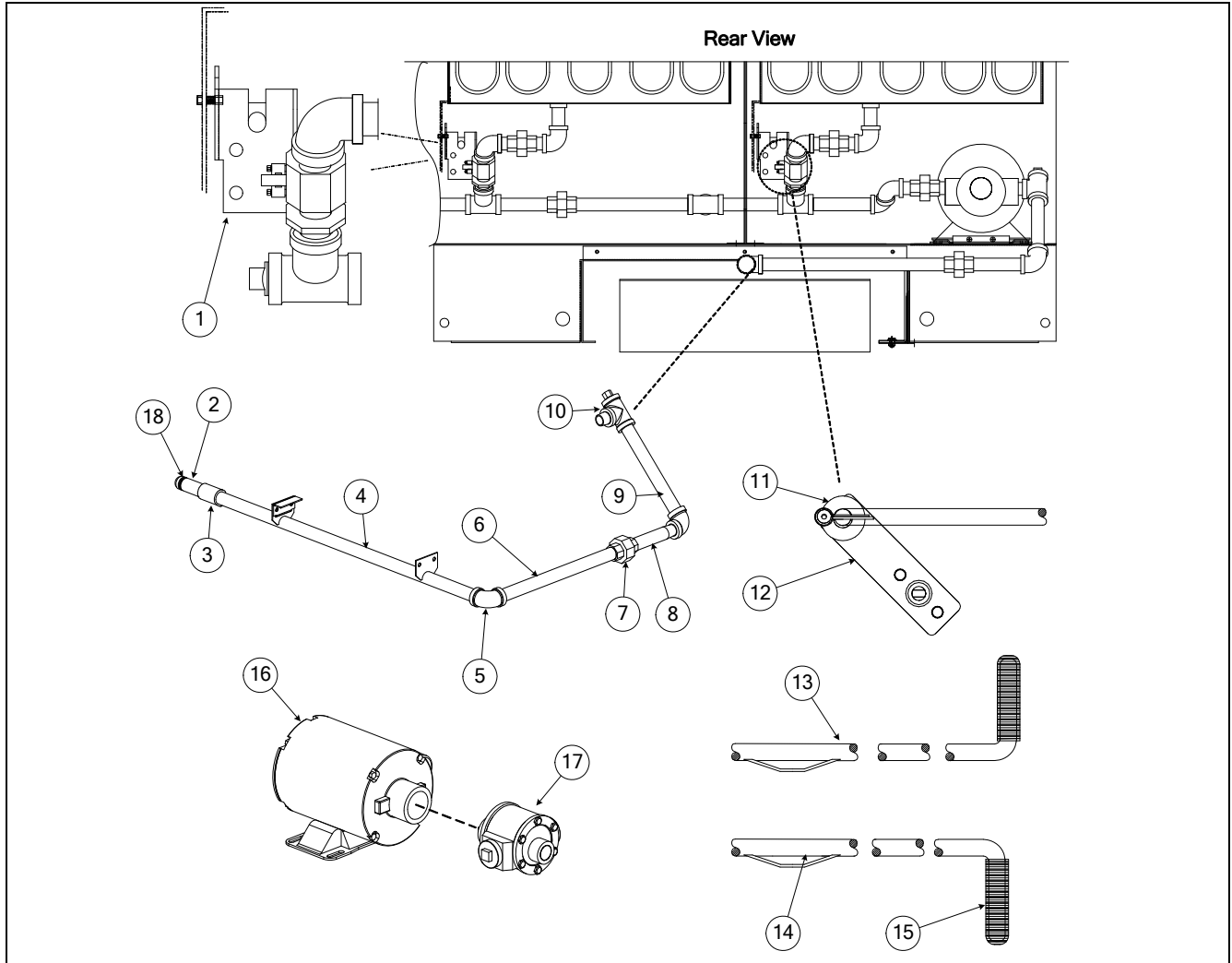

**FRYMASTER DEAN MILLIVOLT GAS FRYERS  
CHAPTER 2: PARTS LIST**

**2.7.1 Oil Return and Oil Flush Components; Fryers with 1½” Drains (cont.)**

ITEM	PART #	COMPONENT
1		<b>Microswitch Bracket Assembly, Oil Return</b>
*	2011233	Bracket, Oil Return Microswitch- Left
*	2021233	Bracket, Oil Return Microswitch- Right
*	8102144	Spacer, Aluminum, 4-40- ¼" x 3/8"
*	8072104	Microswitch, Oil Return
*	8090846	Screw, 4-40 x 1" Slotted Head
*	8090842	Nut, Nylock- 4-40
*	2001341	Bracket, Microswitch Rod
*	8090360	Screw, #8 x ¾" Hex Washer Slotted Head
*	8090803	Bolt, ¼"-20 x ¾" Hex Head Grade 5
*	8090823	Nut, Nylock, ¼"-20
*	8090070	Nut, ¼"-20 Hex S/S
2	8100697	Disconnect, Male- Suction Tube
3	8130608	Coupling, Full- ½" NPT BM
4	8233188	Suction Manifold Assembly
5	8130062	Elbow, 90° BM
6	8130515	Nipple, ½" x 12" NPT BM
7	8130173	Union, ½" NPT BM
8	8130251	Nipple, ½" x 4-½" NPT BM
9	8130672	Nipple, ½" x 8" NPT BM
10		<b>Oil Suction Start Fitting</b>
*	8130022	Nipple- ½" NPT x Close
*	8130156	Plug, ½" NPT Hex Head
*	8130003	Tee, ½" NPT BM
11	8090885	Washer, ⅜" x 1" x .083"
*	8090843	Pin, Cotter- Plated
12	8233344	Handle (Actuator), Oil Return Valve
13	8233187	Handle, Oil Return- Left Fryer-UFF System
14	8233198	Handle, Oil Return- Right Fryer-UFF System
*	8233481	Handle, Oil Flush Valve
15	8160548	Cap, Oil Return Handle- Yellow
*	8160549	Cap, Oil Flush Handle- Blue
16	8102100	Motor, Pump- 120-230V
*	8261987	Motor, Pump Assembly 5 GPM
17	8102098	Pump, 8 GPM
*	8102252	Pump, 5 GPM
*	2101650	Oil Deflector, Oil Return
18	8261392	O-Rings (Pkg. of 5)
*	1062949SP	Line Assembly, Garland Pump Suction
*	KIT4678SP	Wash Down Hose Fittings Kit
*	8073593	Power Cord
*	8073611	Relay, Filter 24A DPDT

\* Not Illustrated

**FRYMASTER DEAN MILLIVOLT GAS FRYERS  
CHAPTER 2: PARTS LIST**

**2.7.2 Oil Return and Oil Flush Components; Fryers with 3" Drains**

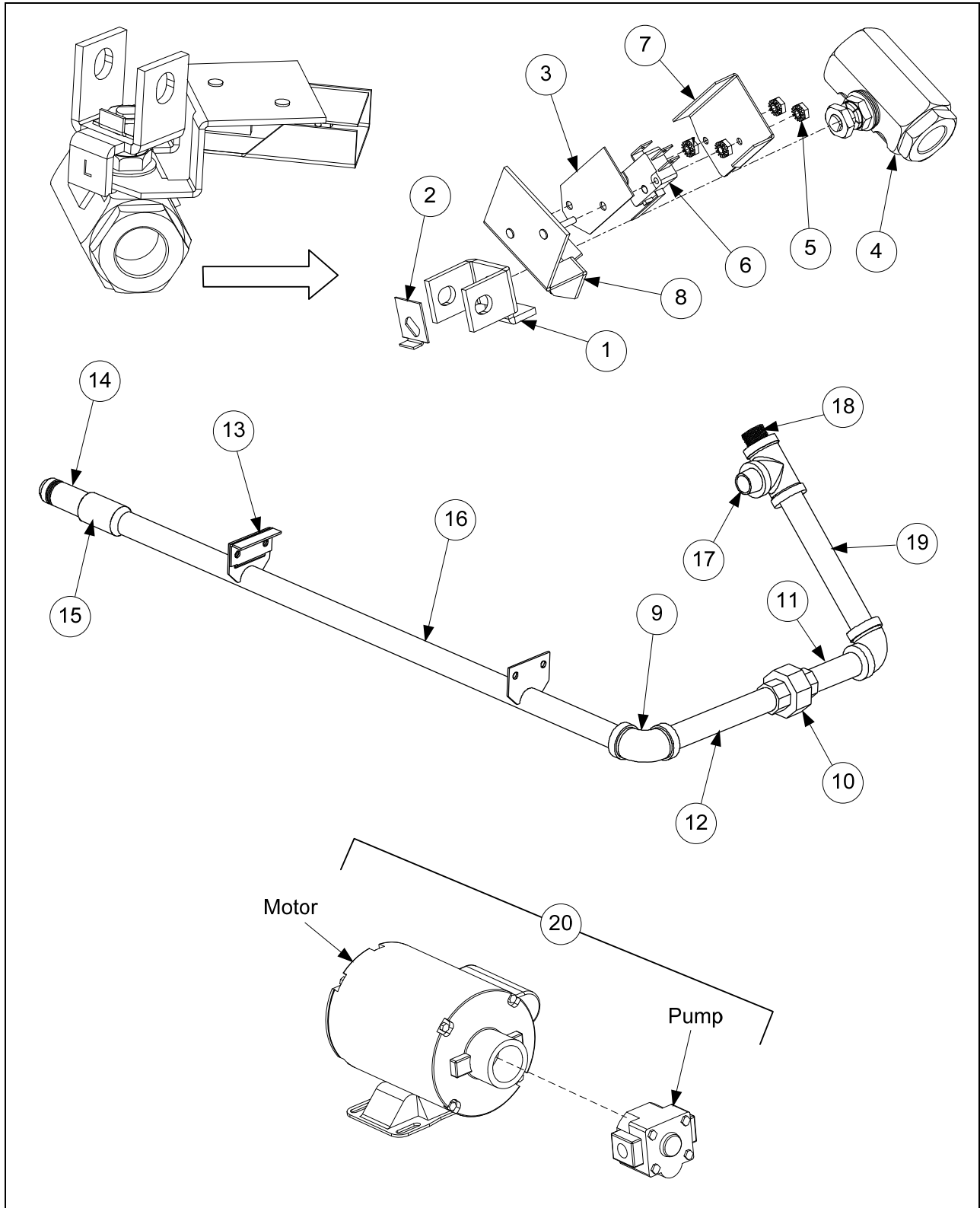

**FRYMASTER DEAN MILLIVOLT GAS FRYERS  
CHAPTER 2: PARTS LIST**

**2.7.2 Oil Return and Oil Flush Components; Fryers with 3" Drains (cont.)**

<b>ITEM</b>	<b>PART #</b>	<b>COMPONENT</b>
	1064006	<b>Microswitch Bracket Assembly, Oil Return</b>
1	9012772	Handle, RF Left
2	9002935	Retainer, Nut
3	8160220	Insulation, RF Switch
4	8100278	Ball Valve, 1/2" Oil Return
5	8261366	Nut, 4-40 Keps hex w/ External Teeth (Pkg. of 25)
6	8072103	Microswitch, Straight Lever (CE)
7	2006806	Cover, Safety Switch
8	1063962	Bracket Assembly, RF Switch
	1061225	<b>Oil Suction Assembly</b>
9	8130062	Elbow, 90° BM
10	8130173	Union, 1/2" NPT 150# BM
11	8130654	Nipple, TBE 1/2" NPT x 4" BM
12	8130674	Nipple, TBE 1/2" NPT x 7.25" BM
13	2001230	Bracket, Front male Manifold
	1060774	<b>Suction Manifold Assembly</b>
14	8100697	Disconnect, Male Suction Tube
15	8130608	Coupling, 1/2" NPT BM Full
16	8233188	Suction Manifold
	1060858	<b>Oil Suction Start Fitting</b>
17	8130022	Nipple, 1/2" NPT Close
18	8130463	Plug, 1/2" Counter Sink
19	8130003	Tee, 1/2" NPT BM
*	2108790	Bracket, Oil Return/ Flush Retainer
*	2008929	Handle, Oil Return
*	2009850	Handle, Oil Return (Application Series "DF" Fryers)
*	8160548	Cap, Oil Return Handle, Yellow
*	8160549	Cap, Oil Return Handle, Blue
20	8102097	Motor/Pump Combo, 120-230V

\* Not Illustrated

**FRYMASTER DEAN MILLIVOLT GAS FRYERS  
CHAPTER 2: PARTS LIST**

**2.8 Under Fryer Filter (UFF) Components**

**2.8.1 SM50 and SM60 Series Fryers (Except IHOP)**

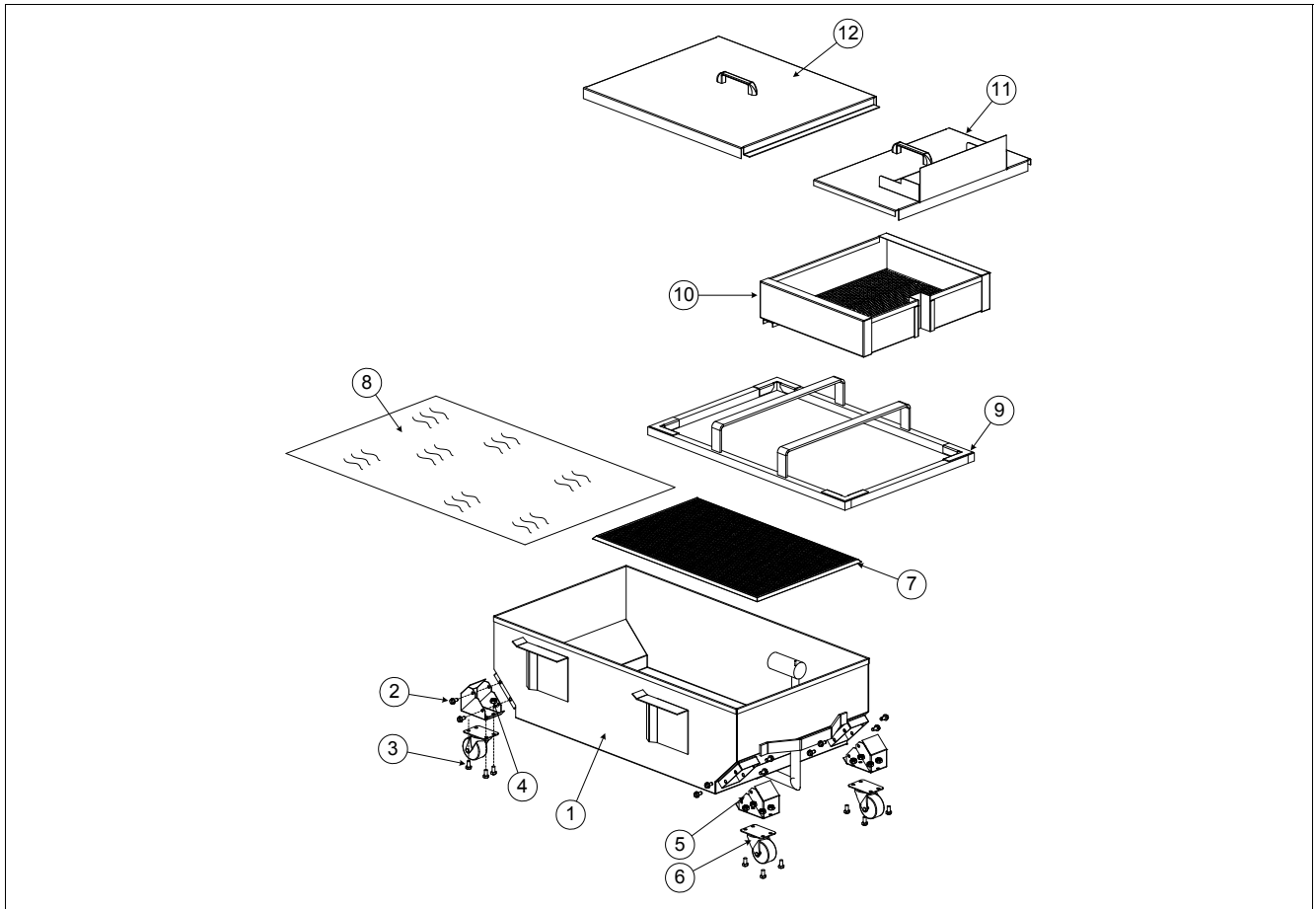

ITEM	PART #	COMPONENT
1	8233576	Filter Pan- UFF 50
*	1062115SP	Filter Pan Assembly- UFF 50
*	1060749SP	Filter Pan Assembly- UFF 60
2	8090805	Screw, 1/4"-20 x 1/2"
3	8090428	Bolt, 1/4"-20 x 1/2" Steel
4	8090820	Nut, Oval Locking- 1/4"-20
5	8234794	Insert, Caster
6	8102805	Caster, 2"-Swivel
7	8233574	Support Grid (Bottom Pan Screen)- UFF 50
*	8233365	Support Grid (Bottom Pan Screen)- UFF 60
8	8030289	Filter Paper, 22" x 34"- UFF 50/60 (100 Sheets)
9	8233573	Hold-down Ring, Weighted- UFF 50
*	8233361	Hold-down Ring, Weighted- UFF 60
10	8234320	Crumb Basket, UFF 50/60
11	1060752SP	Lid Assembly, Front- UFF 50/60
12	1061755SP	Lid Assembly, Rear- UFF 50
*	1060753SP	Lid Assembly, Rear- UFF 60

\* Not Illustrated

**FRYMASTER DEAN MILLIVOLT GAS FRYERS  
CHAPTER 2: PARTS LIST**

**2.8.2 SM50 Series Fryers, IHOP UFF 50 with Filter Leaf**

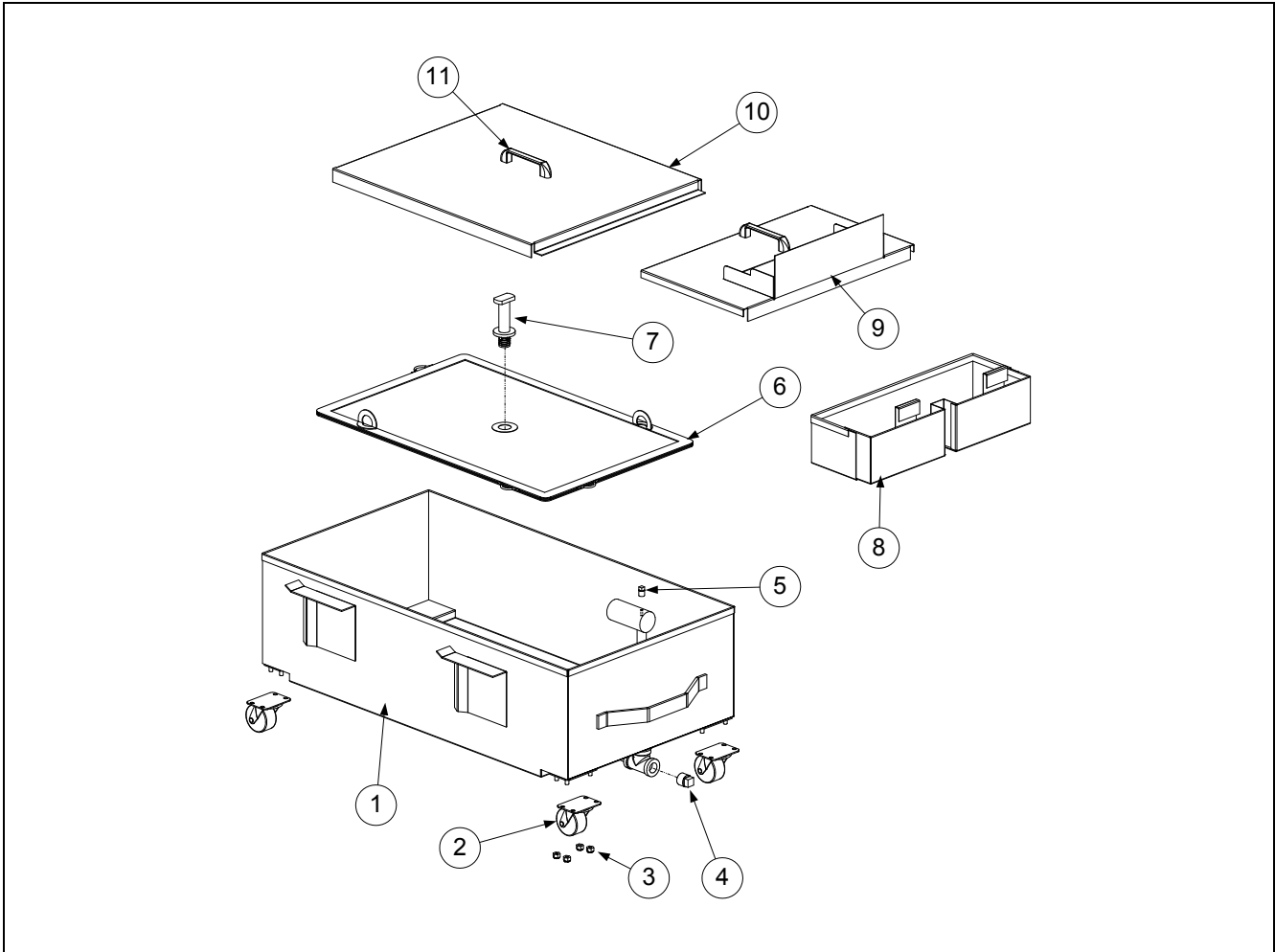

ITEM	PART #	COMPONENT
	1062109SP	Filter Pan Assembly- UFF 50 IHOP (includes items 1-5)
1	8233703	Filter Pan- UFF 50 IHOP
2	8102805	Caster, 2"-Swivel
3	8090823	Nut, Nylock 1/4"-20
4	8130336	Plug, Pipe- S/S- 1/2" NPT
5	8130679	Plug, 1/8" S/S Square Head
6	8102350	Leaf, Filter- UFF 50 IHOP
7	8102351	Handle, Filter Leaf Tee Fitting
8	8233872	Crumb Basket, UFF 50 IHOP
9	1060752SP	Lid Assembly, Front- UFF 50
10	1060753SP	Lid Assembly, Rear- UFF 60
11	8100180	Handle, Filter Lid- Front & Back
*	8090191	Washer, 1/4" Lock- Filter Lid Handle
*	8090918	Screw, #10-24 x 1/2"- Filter Lid Handle

\* Not Illustrated

## FRYMASTER DEAN MILLIVOLT GAS FRYERS CHAPTER 2: PARTS LIST

### 2.8.3 SM80 Series Fryers

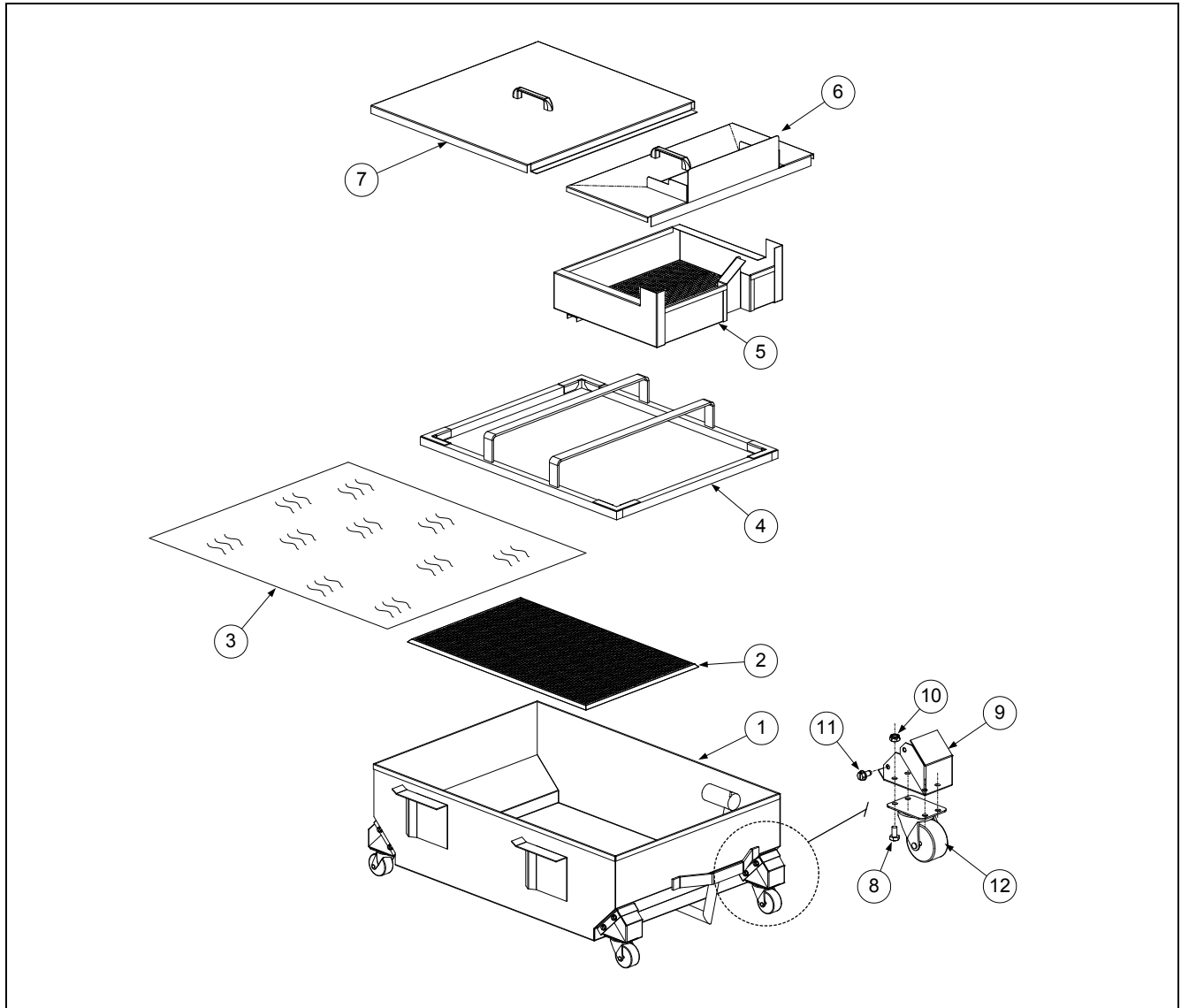

ITEM	PART #	COMPONENT
1	1061584SP	Filter Pan, UFF 80
2	8233365	Support Grid (Bottom Pan Screen) (Use 8234938 for Chili's)
3	8030303	Filter Paper, 26" x 34" (100 Sheets)
4	8233439	Hold-down Ring, Weighted
5	8233443	Crumb Basket
6	1061587SP	Filter Pan Cover, Front
7	1061588SP	Filter Pan Cover, Back
8	8090428	Bolt, 1/4"-20 x 1/2" Steel
9	8234794	Insert, Caster
10	8090820	Nut, Oval Locking- 1/4" -20
11	8090805	Screw, 1/4"-20 x 1/2"
12	8102805	Caster, 2"

**FRYMASTER DEAN MILLIVOLT GAS FRYERS  
CHAPTER 2: PARTS LIST**

**2.9 Single Under Fryer Filter (SUFF) Components**

**2.9.1 SM50 Series Fryers**

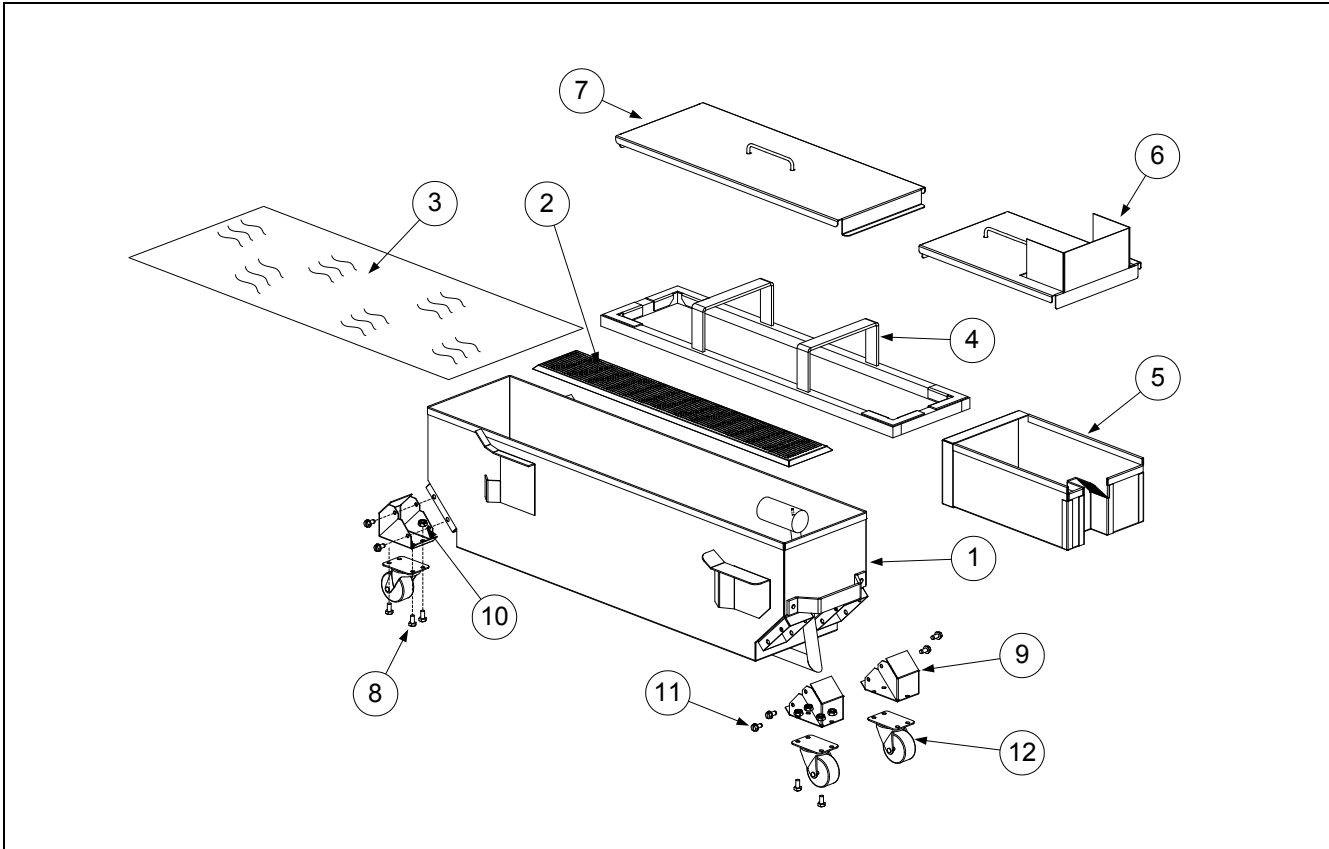

ITEM	PART #	COMPONENT
	1062257SP	Filter Pan Assembly SUFF 50
1	8233796	Filter Pan, SUFF 50
*	8130684	Plug, Hex Socket, 3/8" NPT
*	8130679	Plug, 1/8" S/S Square Head (Female Disconnect)
2	8233790	Support Grid (Bottom Pan Screen)
3	8030317	Paper, Filter- 8-1/4" x 25-3/4"
4	8233795	Hold-down Ring, Weighted
5	8233736	Crumb Basket
6	8233797	Filter Pan Cover, Front
7	8233798	Filter Pan Cover, Back
8	8090428	Bolt, 1/4" -20 x 1/2" Steel
9	8234794	Insert, Caster
10	8090820	Nut, Oval Locking- 1/4" -20
11	8090805	Screw, 1/4" -20 x 1/2"
12	8102805	Caster, 2"

\* Not Illustrated

## FRYMASTER DEAN MILLIVOLT GAS FRYERS CHAPTER 2: PARTS LIST

### 2.9.2 SM60 and SM80 Series Fryers

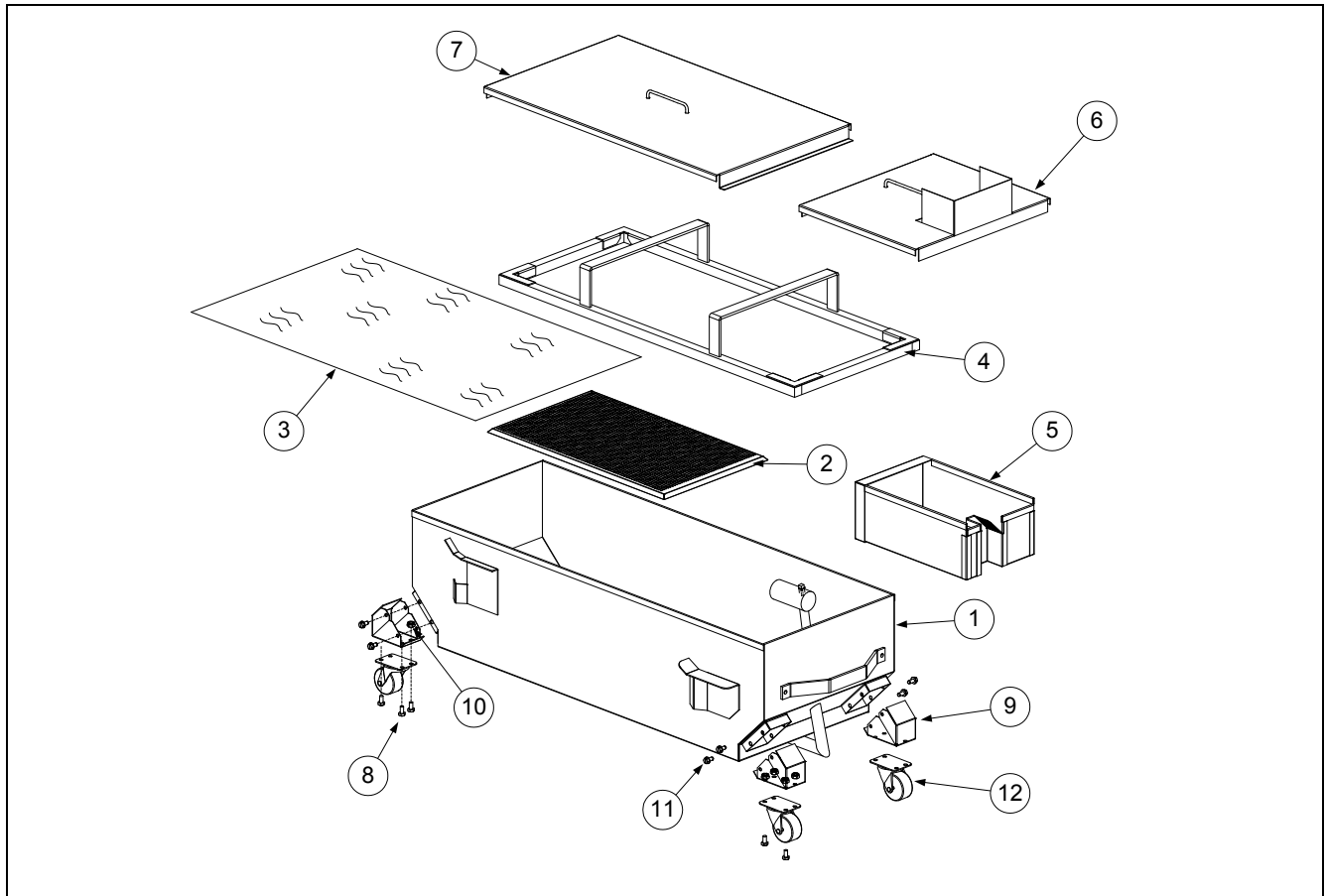

ITEM	PART #	COMPONENT
1	8233774	Filter Pan, SUFF 60 (Use 1062228SP for Assembly)
*	8233821	Filter Pan, SUFF 80 (Use 1062381SP for Assembly)
*	8130684	Plug, Hex Socket, 3/8" NPT
*	8130679	Plug, 1/8" S/S Square Head (Female Disconnect)
2	8233768	Support Grid (Bottom Pan Screen) SUFF 60/80
3	8030289	Paper, Filter- 22" x 34" - SUFF 60/80
4	8233768	Hold-down Ring, Weighted- SUFF 60
*	8233849	Hold-down Ring, Weighted- SUFF 80
5	8233736	Crumb Basket- SUFF 60/80
6	8233766	Filter Pan Cover, Front- SUFF 60
*	8233739	Filter Pan Cover, Front- SUFF 80
7	8233767	Filter Pan Cover, Back- SUFF 60
*	8233741	Filter Pan Cover, Back- SUFF 80
8	8090428	Bolt, 1/4" -20 x 1/2" Steel
9	8234794	Insert, Caster
10	8090820	Nut, Oval Locking- 1/4"-20
11	8090805	Screw, 1/4" -20 x 1/2"
12	8102805	Caster, 2"

\* Not Illustrated

 **Frymaster**  **Dean**

 **Manitowoc**

Shipping Address: 8700 Line Avenue, Shreveport, Louisiana 71106

TEL 1-318-865-1711

FAX (Tech Support) 1-318-219-7135

PRINTED IN THE UNITED STATES

SERVICE HOTLINE  
1-800-551-8633

8195948  
06/2015